

M E T A L R O O F I N G

PRODUCT Catalog

• ROOFING MACHINES

• ROOFING MATERIAL

• ACCESSORIES



“It’s all about the customer.”

To know Englert is to know the man who said those words, Herb Englert, and the vision behind the company. Whether you work with our salespeople or spec our products, when you deal with Englert, you understand the culture of our company and the heart of our business.

It revolves around our core belief that we’re not here to sell you roofing products, machines or accessories, we’re here to help you build your business. We’d love you to buy our products. But, to us, it’s more important that you buy into an ongoing business relationship that will help you build and grow your company.

We do this, as we have since 1966, with a commitment to innovation that continues to raise the bar – and eyebrows – in the building products industry. And we do it every day with our commitment to being your single source for seamless solutions.

After all, as my father Herb once said, “It’s all about the customer.” It still is.

Debbie Tripod

President
Englert, Inc.

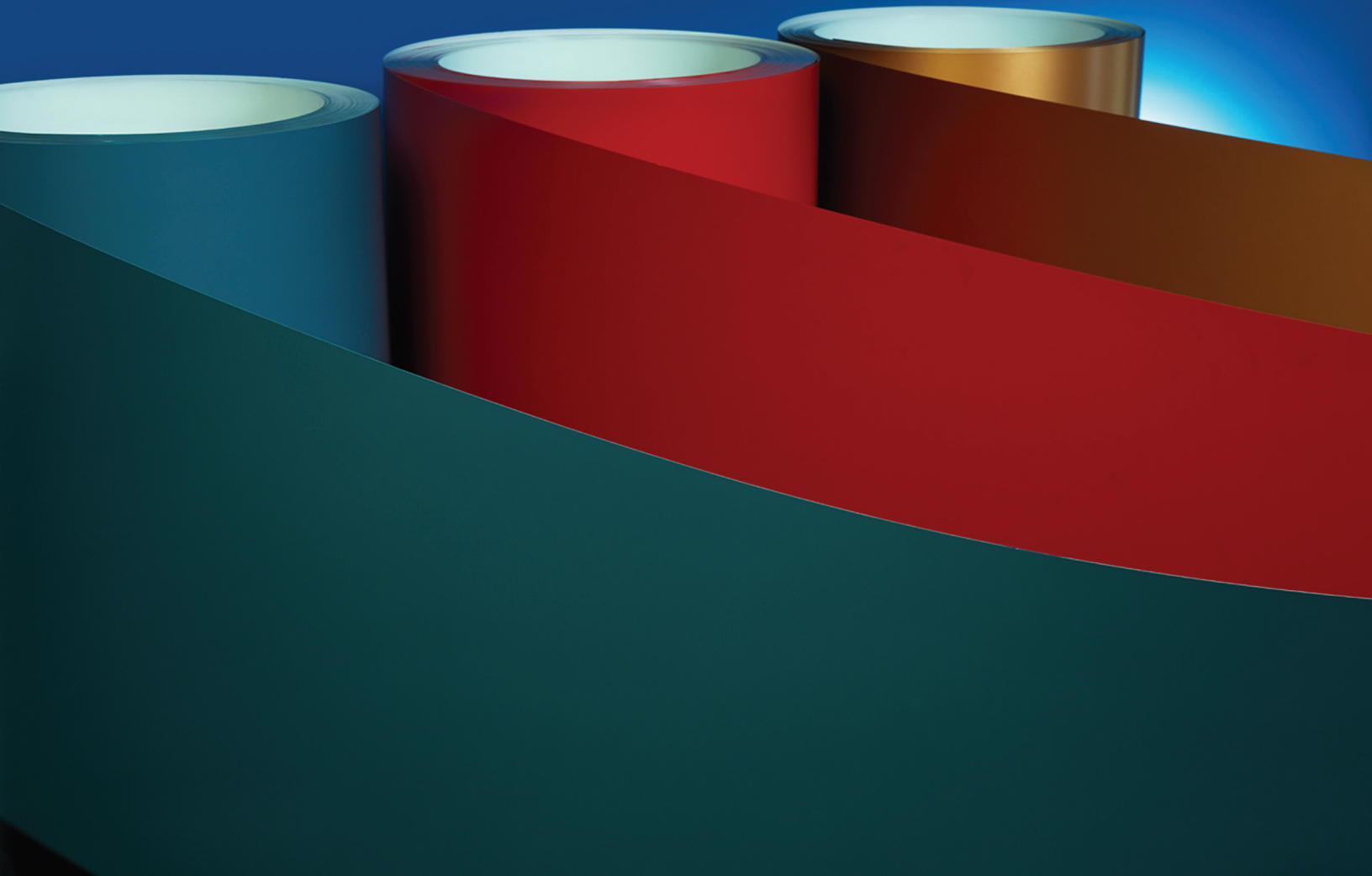
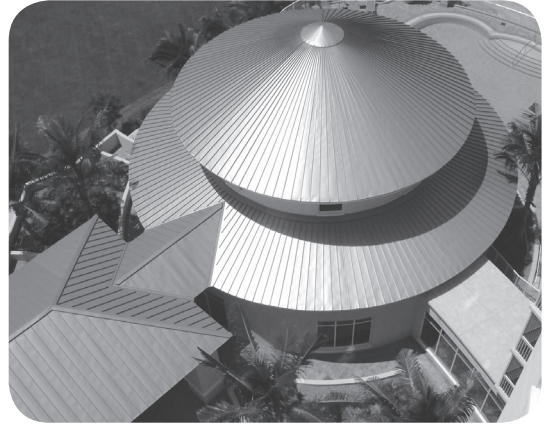

Table of Contents

Steel Roofing Material – Coils	2-5
Steel Roofing Material – Sheets	6
Aluminum Roofing Material – Coils.	7-10
Aluminum Roofing Materials – Sheets	11-12
Specialty Metals – Copper & Zinc	12-13
Edge Metal and Soffit	14
Roofing Clips	15-20
Fasteners and Accessories	21-26
Underlayment	26
MetalMan Roofing Machines	27-30
Curvers and Seamers.	31-35
MetalMan 770 7" Box Gutter Machine.	36
RAS Folders and Shears.	37
Material Conversion and Usage Information	38
Installation Common Sense and Material Handling.	39
Terms and Conditions.	40



Steel Roofing Coil 24" x 24 Gauge (.024) AZ-50 Galvalume/Kynar 500 Finish - Stocking

PART NO.	COLOR	PART NO.	COLOR
2424BD	Burgundy	2424PB	Pacific Blue
2424BW	Bone White	2424PG	Patina Green
2424CG	Charcoal Gray	2424RB	Royal Blue
2424CR	Colonial Red	2424SB	Slate Blue
2424DB	Dark Bronze	2424SG	Slate Gray
2424DG	Dove Gray	2424SS	Sandstone
2424DR	Deep Red	2424ST	Sierra Tan
2424EM	Everglade Moss	2424SW	Stone White
2424FG	Forest Green	2424SN	SunNet Blue
2424HG	Hartford Green	2424TC	Terracotta
2424HL	Hemlock Green	2424MC	Metallic Copper
2424MA	Mansard Brown	2424CH	Champagne
2424MB	Medium Bronze	2424PW	Prewathered Galvalume
2424MT	Matte Black	06410A	Galvalume Plus



SPECIFICATIONS:

- Coil ID: 20"
- Approximate Coil Size 1,000 & 2,000 Sq. Ft.
- **CAUTION!** Metallic Copper, Champagne and Prewathered Galvalume are directional paints. (Do not mix lots on one roof plane.)
- Galvalume Plus is AZ55 with a clear acrylic coating. (Aesthetics for Mill Finish products are not guaranteed.)

Steel Roofing Coil 22" x 24 Gauge (.024) AZ-50 Galvalume / Kynar 500 Finish - Standard, Non-Stocking

PART NO.	COLOR	PART NO.	COLOR
2422BD	Burgundy	2422PB	Pacific Blue
2422BW	Bone White	2422PG	Patina Green
2422CG	Charcoal Gray	2422RB	Royal Blue
2422CR	Colonial Red	2422SB	Slate Blue
2422DB	Dark Bronze	2422SG	Slate Gray
2422DG	Dove Gray	2422SS	Sandstone
2422DR	Deep Red	2422ST	Sierra Tan
2422EM	Everglade Moss	2422SW	Stone White
2422FG	Forest Green	2422SN	SunNet Blue
2422HG	Hartford Green	2422TC	Terracotta
2422HL	Hemlock Green	2422MC	Metallic Copper
2422MA	Mansard Brown	2422CH	Champagne
2422MB	Medium Bronze	2422PW	Prewathered Galvalume
2422MT	Matte Black	06310A	Galvalume Plus



SPECIFICATIONS:

- Coil ID: 20"
- Approximate Coil Size 1,000 & 2,000 Sq. Ft.
- **CAUTION!** Metallic Copper, Champagne and Prewathered Galvalume are directional paints. (Do not mix lots on one roof plane.)
- Galvalume Plus is AZ55 with a clear acrylic coating. (Aesthetics for Mill Finish products are not guaranteed.)

* Minimum ordering quantities may apply. Please consult with an Englert representative before ordering. Specifications subject to change without notice.



Steel Roofing Coil 20" x 24 Gauge (.024) AZ-50 Galvalume / Kynar 500 Finish - Stocking

PART NO.	COLOR	PART NO.	COLOR
2420BD	Burgundy	2420PB	Pacific Blue
2420BW	Bone White	2420PG	Patina Green
2420CG	Charcoal Gray	2420RB	Royal Blue
2420CR	Colonial Red	2420SB	Slate Blue
2420DB	Dark Bronze	2420SG	Slate Gray
2420DG	Dove Gray	2420SS	Sandstone
2420DR	Deep Red	2420ST	Sierra Tan
2420EM	Everglade Moss	2420SW	Stone White
2420FG	Forest Green	2420SN	SunNet Blue
2420HG	Hartford Green	2420TC	Terracotta
2420HL	Hemlock Green	2420MC	Metallic Copper
2420MA	Mansard Brown	2420CH	Champagne
2420MB	Medium Bronze	2420PW	Prewathered Galvalume
2420MT	Matte Black	06411A	Galvalume Plus

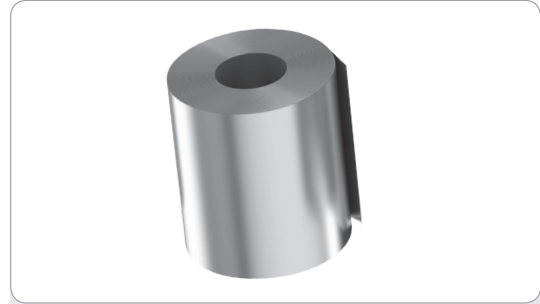

SPECIFICATIONS:

- Coil ID: 20"
- Approximate Coil Size 1,000 & 2,000 Sq. Ft.
- **CAUTION!** Metallic Copper, Champagne and Prewathered Galvalume are directional paints. (Do not mix lots on one roof plane.)
- Galvalume Plus is AZ55 with a clear acrylic coating. (Aesthetics for Mill Finish products are not guaranteed.)

Steel Roofing Coil 16" x 24 Gauge (.024) AZ-50 Galvalume / Kynar 500 Finish - Standard, Non-Stocking

PART NO.	COLOR	PART NO.	COLOR
2416BD	Burgundy	2416PB	Pacific Blue
2416BW	Bone White	2416PG	Patina Green
2416CG	Charcoal Gray	2416RB	Royal Blue
2416CR	Colonial Red	2416SB	Slate Blue
2416DB	Dark Bronze	2416SG	Slate Gray
2416DG	Dove Gray	2416SS	Sandstone
2416DR	Deep Red	2416ST	Sierra Tan
2416EM	Everglade Moss	2416SW	Stone White
2416FG	Forest Green	2416SN	SunNet Blue
2416HG	Hartford Green	2416TC	Terracotta
2416HL	Hemlock Green	2416MC	Metallic Copper
2416MA	Mansard Brown	2416CH	Champagne
2416MB	Medium Bronze	2416PW	Prewathered Galvalume
2416MT	Matte Black	06513A	Galvalume Plus



SPECIFICATIONS:

- Coil ID: 20"
- 1,000 Sq. Ft. Minimum Order.
- Approximate Coil Size 1,000 & 2,000 Sq. Ft.
- **CAUTION!** Metallic Copper, Champagne and Prewathered Galvalume are directional paints. (Do not mix lots on one roof plane.)
- Galvalume Plus is AZ55 with a clear acrylic coating. (Aesthetics for Mill Finish products are not guaranteed.)

* Minimum ordering quantities may apply. Please consult with an Englert representative before ordering. Specifications subject to change without notice.

Steel Roofing Coil 48-1/4" x 24 Gauge (.024) "Master Coil"
AZ-50 Galvalume / Kynar 500 Finish – Non-Stocking

PART NO.	COLOR	PART NO.	COLOR
2248BD	Burgundy	2248PB	Pacific Blue
2248BW	Bone White	2248PG	Patina Green
2248CG	Charcoal Gray	2248RB	Royal Blue
2248CR	Colonial Red	2248SB	Slate Blue
2248DB	Dark Bronze	2248SG	Slate Gray
2248DG	Dove Gray	2248SS	Sandstone
2248DR	Deep Red	2248ST	Sierra Tan
2248EM	Everglade Moss	2248SW	Stone White
2248FG	Forest Green	2248SN	SunNet Blue
2248HG	Hartford Green	2248TC	Terracotta
2248HL	Hemlock Green	2248MC	Metallic Copper
2248MA	Mansard Brown	2248CH	Champagne
2248MB	Medium Bronze	2248PW	Prewathered Galvalume
2248MT	Matte Black	20483A	Galvalume Plus



SPECIFICATIONS:

- Coil ID: 20"
- Master Coil is sold by the pound.
- **CAUTION!** Metallic Copper, Champagne and Prewathered Galvalume are directional paints. (Do not mix lots on one roof plane.)
- Galvalume Plus is AZ55 with a clear acrylic coating. (Aesthetics for Mill Finish products are not guaranteed.)

Steel Roofing Coil 20" x 26 Gauge (.018) AZ-50 Galvalume / Kynar 500 Finish – Non-Stocking

PART NO.	COLOR	PART NO.	COLOR
1820BD	Burgundy	1820PB	Pacific Blue
1820BW	Bone White	1820PG	Patina Green
1820CG	Charcoal Gray	1820RB	Royal Blue
1820CR	Colonial Red	1820SB	Slate Blue
1820DB	Dark Bronze	1820SG	Slate Gray
1820DG	Dove Gray	1820SS	Sandstone
1820DR	Deep Red	1820ST	Sierra Tan
1820EM	Everglade Moss	1820SW	Stone White
1820FG	Forest Green	1820SN	SunNet Blue
1820HG	Hartford Green	1820TC	Terracotta
1820HL	Hemlock Green	1820MC	Metallic Copper
1820MA	Mansard Brown	1820CH	Champagne
1820MB	Medium Bronze	1820PW	Prewathered Galvalume
1820MT	Matte Black	06385A	Galvalume Plus



SPECIFICATIONS:

- Coil ID: 20"
- Master Coil is sold by the pound.
- **CAUTION!** Metallic Copper, Champagne and Prewathered Galvalume are directional paints. (Do not mix lots on one roof plane.)
- Galvalume Plus is AZ55 with a clear acrylic coating. (Aesthetics for Mill Finish products are not guaranteed.)

* Minimum ordering quantities may apply. Please consult with an Englert representative before ordering. Specifications subject to change without notice.



Steel Roofing Coil 24" x 26 Gauge (.018) AZ-50 Galvalume / Kynar 500 Finish - Stocking

PART NO.	COLOR	PART NO.	COLOR
1824BD	Burgundy	1824PB	Pacific Blue
1824BW	Bone White	1824PG	Patina Green
1824CG	Charcoal Gray	1824RB	Royal Blue
1824CR	Colonial Red	1824SB	Slate Blue
1824DB	Dark Bronze	1824SG	Slate Gray
1824DG	Dove Gray	1824SS	Sandstone
1824DR	Deep Red	1824ST	Sierra Tan
1824EM	Everglade Moss	1824SW	Stone White
1824FG	Forest Green	1824SN	SunNet Blue
1824HG	Hartford Green	1824TC	Terracotta
1824HL	Hemlock Green	1824MC	Metallic Copper
1824MA	Mansard Brown	1824CH	Champagne
1824MB	Medium Bronze	1824PW	Prewathered Galvalume
1824MT	Matte Black	06380A	Galvalume Plus



SPECIFICATIONS:

- Coil ID: 20"
- Approximate Coil Size 1,000 & 2,000 Sq. Ft.
- **CAUTION!** Metallic Copper, Champagne and Prewathered Galvalume are directional paints. (Do not mix lots on one roof plane.)
- Galvalume Plus is AZ55 with a clear acrylic coating. (Aesthetics for Mill Finish products are not guaranteed.)

Steel Roofing Coil 48-1/4" x 26 Gauge (.018) "Master Coil" AZ-50 Galvalume / Kynar 500 Finish - Non-Stocking

PART NO.	COLOR	PART NO.	COLOR
2184BD	Burgundy	2184PB	Pacific Blue
2184BW	Bone White	2184PG	Patina Green
2184CG	Charcoal Gray	2184RB	Royal Blue
2184CR	Colonial Red	2184SB	Slate Blue
2184DB	Dark Bronze	2184SG	Slate Gray
2184DG	Dove Gray	2184SS	Sandstone
2184DR	Deep Red	2184ST	Sierra Tan
2184EM	Everglade Moss	2184SW	Stone White
2184FG	Forest Green	2184SN	SunNet Blue
2184HG	Hartford Green	2184TC	Terracotta
2184HL	Hemlock Green	2184MC	Metallic Copper
2184MA	Mansard Brown	2184CH	Champagne
2184MB	Medium Bronze	2184PW	Prewathered Galvalume
2184MT	Matte Black	20484A	Galvalume Plus



SPECIFICATIONS:

- Coil ID: 20"
- Master Coil is sold by the pound.
- **CAUTION!** Metallic Copper, Champagne and Prewathered Galvalume are directional paints. (Do not mix lots on one roof plane.)
- Galvalume Plus is AZ55 with a clear acrylic coating. (Aesthetics for Mill Finish products are not guaranteed.)

* Minimum ordering quantities may apply. Please consult with an Englert representative before ordering. Specifications subject to change without notice.

Steel Sheets 4 x 10 x 24 Gauge (.024) AZ-50 Galvalume / Kynar 500 Finish – Stocking

PART NO.	COLOR	PART NO.	COLOR
2410BD	Burgundy	2410PB	Pacific Blue
2410BW	Bone White	2410PG	Patina Green
2410CG	Charcoal Gray	2410RB	Royal Blue
2410CR	Colonial Red	2410SB	Slate Blue
2410DB	Dark Bronze	2410SG	Slate Gray
2410DG	Dove Gray	2410SS	Sandstone
2410DR	Deep Red	2410ST	Sierra Tan
2410EM	Everglade Moss	2410SW	Stone White
2410FG	Forest Green	2410SN	SunNet Blue
2410HG	Hartford Green	2410TC	Terracotta
2410HL	Hemlock Green	2410MC	Metallic Copper
2410MA	Mansard Brown	2410CH	Champagne
2410MB	Medium Bronze	2410PW	Prewathered Galvalume
2410MT	Matte Black	06201A	Galvalume Plus

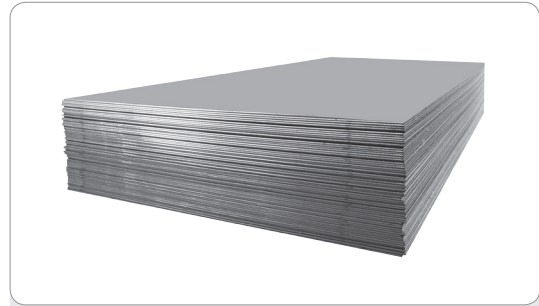

SPECIFICATIONS:

- 50 sheets to a skid.
- Sheets come standard with strippable clear film. (Except Galvalume Plus)
- Storage of sheets, see page 39.
- **CAUTION!** Metallic Copper, Champagne and Prewathered Galvalume are directional paints. (Do not mix lots on one roof plan.)
- Galvalume Plus is AZ55 with a clear acrylic coating. (Aesthetics for Mill Finish products are not guaranteed.)

Steel Sheets 4 x 10 x 26 Gauge (.018) AZ-50 Galvalume / Kynar 500 Finish – Stocking

PART NO.	COLOR	PART NO.	COLOR
1810BD	Burgundy	1810PB	Pacific Blue
1810BW	Bone White	1810PG	Patina Green
1810CG	Charcoal Gray	1810RB	Royal Blue
1810CR	Colonial Red	1810SB	Slate Blue
1810DB	Dark Bronze	1810SG	Slate Gray
1810DG	Dove Gray	1810SS	Sandstone
1810DR	Deep Red	1810ST	Sierra Tan
1810EM	Everglade Moss	1810SW	Stone White
1810FG	Forest Green	1810SN	SunNet Blue
1810HG	Hartford Green	1810TC	Terracotta
1810HL	Hemlock Green	1810MC	Metallic Copper
1810MA	Mansard Brown	1810CH	Champagne
1810MB	Medium Bronze	1810PW	Prewathered Galvalume
1810MT	Matte Black	06160A	Galvalume Plus



SPECIFICATIONS:

- 50 sheets to a skid.
- Sheets come standard with strippable clear film. (Except Galvalume Plus)
- Storage of sheets, see page 39.
- **CAUTION!** Metallic Copper, Champagne and Prewathered Galvalume are directional paints.
- Galvalume Plus is AZ55 with a clear acrylic coating. (Aesthetics for Mill Finish products are not guaranteed.)

* Minimum ordering quantities may apply. Please consult with an Englert representative before ordering. Specifications subject to change without notice.



Aluminum Roofing Coil 24" x .032 #3105-H24 Alloy / Kynar 500 Finish - Stocking

PART NO.	COLOR	PART NO.	COLOR
2432BD	Burgundy	2432PB	Pacific Blue
2432BW	Bone White	2432PG	Patina Green
2432CG	Charcoal Gray	2432RB	Royal Blue
2432CR	Colonial Red	2432SB	Slate Blue
2432DB	Dark Bronze	2432SG	Slate Gray
2432DG	Dove Gray	2432SS	Sandstone
2432DR	Deep Red	2432ST	Sierra Tan
2432EM	Everglade Moss	2432SW	Stone White
2432FG	Forest Green	2432SN	SunNet Blue
2432HG	Hartford Green	2432TC	Terracotta
2432HL	Hemlock Green	2432MC	Metallic Copper
2432MA	Mansard Brown	2432CH	Champagne
2432MB	Medium Bronze	2432PW	Prewathered Galvalume
2432MT	Matte Black		



SPECIFICATIONS:

- Coil ID: 20"
- Approximate Coil Size 1,000 & 2,000 Sq. Ft.
- **CAUTION!** Metallic Copper, Champagne and Prewathered Galvalume are directional paints. (Do not mix lots on one roof plane.)

Aluminum Roofing Coil 20" x .032 #3105-H24 Alloy / Kynar 500 Finish - Stocking

PART NO.	COLOR	PART NO.	COLOR
3220BD	Burgundy	3220PB	Pacific Blue
3220BW	Bone White	3220PG	Patina Green
3220CG	Charcoal Gray	3220RB	Royal Blue
3220CR	Colonial Red	3220SB	Slate Blue
3220DB	Dark Bronze	3220SG	Slate Gray
3220DG	Dove Gray	3220SS	Sandstone
3220DR	Deep Red	3220ST	Sierra Tan
3220EM	Everglade Moss	3220SW	Stone White
3220FG	Forest Green	3220SN	SunNet Blue
3220HG	Hartford Green	3220TC	Terracotta
3220HL	Hemlock Green	3220MC	Metallic Copper
3220MA	Mansard Brown	3220CH	Champagne
3220MB	Medium Bronze	3220PW	Prewathered Galvalume
3220MT	Matte Black		



SPECIFICATIONS:

- Coil ID: 20"
- Approximate Coil Size 1,000 & 2,000 Sq. Ft.
- **CAUTION!** Metallic Copper, Champagne and Prewathered Galvalume are directional paints. (Do not mix lots on one roof plane.)

* Minimum ordering quantities may apply. Please consult with an Englert representative before ordering. Specifications subject to change without notice.

Aluminum Roofing Coil 16" x .032 #3105-H24 Alloy / Kynar 500 Finish – Stocking

PART NO.	COLOR	PART NO.	COLOR
3216BD	Burgundy	3216PB	Pacific Blue
3216BW	Bone White	3216PG	Patina Green
3216CG	Charcoal Gray	3216RB	Royal Blue
3216CR	Colonial Red	3216SB	Slate Blue
3216DB	Dark Bronze	3216SG	Slate Gray
3216DG	Dove Gray	3216SS	Sandstone
3216DR	Deep Red	3216ST	Sierra Tan
3216EM	Everglade Moss	3216SW	Stone White
3216FG	Forest Green	3216SN	SunNet Blue
3216HG	Hartford Green	3216TC	Terracotta
3216HL	Hemlock Green	3216MC	Metallic Copper
3216MA	Mansard Brown	3216CH	Champagne
3216MB	Medium Bronze	3216PW	Prewheathered Galvalume
3216MT	Matte Black		



SPECIFICATIONS:

- Coil ID: 20"
- Approximate Coil Size 1,000 & 2,000 Sq. Ft.
- **CAUTION!** Metallic Copper, Champagne and Prewheathered Galvalume are directional paints. (Do not mix lots on one roof plane.)

Aluminum Roofing Coil 24" x .040 #3105-H24 Alloy / Kynar 500 Finish – Standard, Non-Stocking

PART NO.	COLOR	PART NO.	COLOR
2440BD	Burgundy	2440PB	Pacific Blue
2440BW	Bone White	2440PG	Patina Green
2440CG	Charcoal Gray	2440RB	Royal Blue
2440CR	Colonial Red	2440SB	Slate Blue
2440DB	Dark Bronze	2440SG	Slate Gray
2440DG	Dove Gray	2440SS	Sandstone
2440DR	Deep Red	2440ST	Sierra Tan
2440EM	Everglade Moss	2440SW	Stone White
2440FG	Forest Green	2440SN	SunNet Blue
2440HG	Hartford Green	2440TC	Terracotta
2440HL	Hemlock Green	2440MC	Metallic Copper
2440MA	Mansard Brown	2440CH	Champagne
2440MB	Medium Bronze	2440PW	Prewheathered Galvalume
2440MT	Matte Black		



SPECIFICATIONS:

- Coil ID: 20"
- Approximate Coil Size 1,000 & 2,000 Sq. Ft.
- **CAUTION!** Metallic Copper, Champagne and Prewheathered Galvalume are directional paints. (Do not mix lots on one roof plane.)



* Minimum ordering quantities may apply. Please consult with an Englert representative before ordering. Specifications subject to change without notice.

Aluminum Roofing Coil 48-1/4" x .032 "Master Coil"

#3105-H24 Alloy / Kynar 500 Finish - Standard, Non-Stocking

PART NO.	COLOR	PART NO.	COLOR
2328BD	Burgundy	2328PB	Pacific Blue
2328BW	Bone White	2328PG	Patina Green
2328CG	Charcoal Gray	2328RB	Royal Blue
2328CR	Colonial Red	2328SB	Slate Blue
2328DB	Dark Bronze	2328SG	Slate Gray
2328DG	Dove Gray	2328SS	Sandstone
2328DR	Deep Red	2328ST	Sierra Tan
2328EM	Everglade Moss	2328SW	Stone White
2328FG	Forest Green	2328SN	SunNet Blue
2328HG	Hartford Green	2328TC	Terracotta
2328HL	Hemlock Green	2328MC	Metallic Copper
2328MA	Mansard Brown	2328CH	Champagne
2328MB	Medium Bronze	2328PW	Prewathered Galvalume
2328MT	Matte Black		

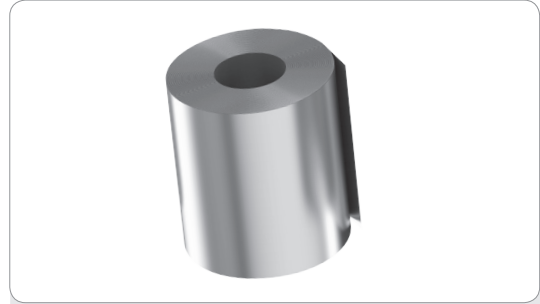

SPECIFICATIONS:

- Coil ID: 20"
- Master Coil is sold by the pound.
- **CAUTION!** Metallic Copper, Champagne and Prewathered Galvalume are directional paints. (Do not mix lots on one roof plane.)

Aluminum Roofing Coil 48-1/4" x .040 "Master Coil"

#3105-H24 Alloy / Kynar 500 Finish - Standard, Non-Stocking

PART NO.	COLOR	PART NO.	COLOR
2408BD	Burgundy	2408PB	Pacific Blue
2408BW	Bone White	2408PG	Patina Green
2408CG	Charcoal Gray	2408RB	Royal Blue
2408CR	Colonial Red	2408SB	Slate Blue
2408DB	Dark Bronze	2408SG	Slate Gray
2408DG	Dove Gray	2408SS	Sandstone
2408DR	Deep Red	2408ST	Sierra Tan
2408EM	Everglade Moss	2408SW	Stone White
2408FG	Forest Green	2408SN	SunNet Blue
2408HG	Hartford Green	2408TC	Terracotta
2408HL	Hemlock Green	2408MC	Metallic Copper
2408MA	Mansard Brown	2408CH	Champagne
2408MB	Medium Bronze	2408PW	Prewathered Galvalume
2408MT	Matte Black		



SPECIFICATIONS:

- Coil ID: 20"
- Master Coil is sold by the pound.
- **CAUTION!** Metallic Copper, Champagne and Prewathered Galvalume are directional paints. (Do not mix lots on one roof plane.)

* Minimum ordering quantities may apply. Please consult with an Englert representative before ordering. Specifications subject to change without notice.

Aluminum Roofing Coil 48" x .050 "Master Coil"

#3105-H24 Alloy / Kynar 500 Finish – Standard, Non-Stocking

PART NO.	COLOR	PART NO.	COLOR
2508BD	Burgundy	2508PB	Pacific Blue
2508BW	Bone White	2508PG	Patina Green
2508CG	Charcoal Gray	2508RB	Royal Blue
2508CR	Colonial Red	2508SB	Slate Blue
2508DB	Dark Bronze	2508SG	Slate Gray
2508DG	Dove Gray	2508SS	Sandstone
2508DR	Deep Red	2508ST	Sierra Tan
2508EM	Everglade Moss	2508SW	Stone White
2508FG	Forest Green	2508SN	SunNet Blue
2508HG	Hartford Green	2508TC	Terracotta
2508HL	Hemlock Green	2508MC	Metallic Copper
2508MA	Mansard Brown	2508CH	Champagne
2508MB	Medium Bronze	2508PW	Prewathered Galvalume
2508MT	Matte Black		



SPECIFICATIONS:

- Coil ID: 20"
- Master Coil is sold by the pound.
- Approximate Coil Size 1,000 & 2,000 Sq. Ft.
- **CAUTION!** Metallic Copper, Champagne and Prewathered Galvalume are directional paints. (Do not mix lots on one roof plane.)



* Minimum ordering quantities may apply. Please consult with an Englert representative before ordering. Specifications subject to change without notice.

Aluminum Sheets 4 x 10 x .032

#3105-H24 Alloy / Kynar 500 Finish - Stocking

PART NO.	COLOR	PART NO.	COLOR
3210BD	Burgundy	3210PB	Pacific Blue
3210BW	Bone White	3210PG	Patina Green
3210CG	Charcoal Gray	3210RB	Royal Blue
3210CR	Colonial Red	3210SB	Slate Blue
3210DB	Dark Bronze	3210SG	Slate Gray
3210DG	Dove Gray	3210SS	Sandstone
3210DR	Deep Red	3210ST	Sierra Tan
3210EM	Everglade Moss	3210SW	Stone White
3210FG	Forest Green	3210SN	SunNet Blue
3210HG	Hartford Green	3210TC	Terracotta
3210HL	Hemlock Green	3210MC	Metallic Copper
3210MA	Mansard Brown	3210CH	Champagne
3210MB	Medium Bronze	3210PW	Prewathered Galvalume
3210MT	Matte Black	00839A	Mill Finish

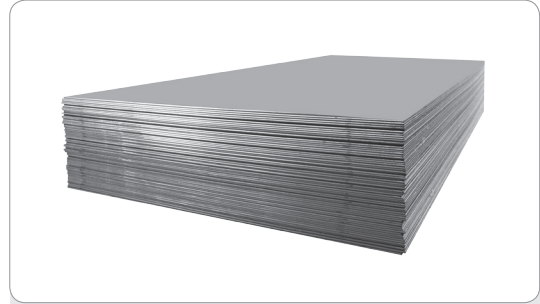

SPECIFICATIONS:

- 50 sheets to a skid.
- Sheets come standard with strippable clear film. (Except Mill Finish)
- Storage of sheets, see page 39.
- **CAUTION!** Metallic Copper, Champagne and Prewathered Galvalume are directional paints. (Aesthetics for Mill Finish products are not guaranteed.)

Aluminum Sheets 4 x 10 x .040

#3105-H24 Alloy / Kynar 500 Finish - Standard, Non-Stocking

PART NO.	COLOR	PART NO.	COLOR
1040BD	Burgundy	1040PB	Pacific Blue
1040BW	Bone White	1040PG	Patina Green
1040CG	Charcoal Gray	1040RB	Royal Blue
1040CR	Colonial Red	1040SB	Slate Blue
1040DB	Dark Bronze	1040SG	Slate Gray
1040DG	Dove Gray	1040SS	Sandstone
1040DR	Deep Red	1040ST	Sierra Tan
1040EM	Everglade Moss	1040SW	Stone White
1040FG	Forest Green	1040SN	SunNet Blue
1040HG	Hartford Green	1040TC	Terracotta
1040HL	Hemlock Green	1040MC	Metallic Copper
1040MA	Mansard Brown	1040CH	Champagne
1040MB	Medium Bronze	1040PW	Prewathered Galvalume
1040MT	Matte Black	00875A	Mill Finish

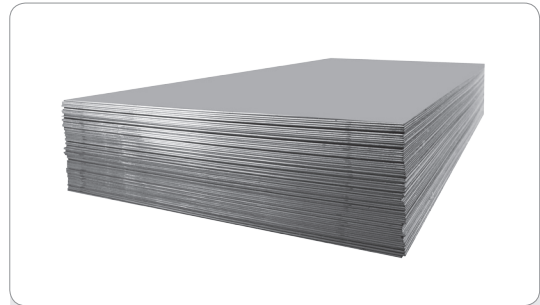

SPECIFICATIONS:

- 50 sheets to a skid.
- *Denotes in stock in that gauge and color.
- All other colors 100 sheet minimum.
- Sheets come standard with strippable clear film. (Except Mill Finish)
- Storage of sheets, see page 39.
- **CAUTION!** Metallic Copper, Champagne and Prewathered Galvalume are directional paints. (Aesthetics for Mill Finish products are not guaranteed.)

* Minimum ordering quantities may apply. Please consult with an Englert representative before ordering. Specifications subject to change without notice.

Aluminum Sheets 4 x 10 x .050

#3105-H24 Alloy / Kynar 500 Finish – Standard, Non-Stocking

PART NO.	COLOR	PART NO.	COLOR
1050BD	Burgundy	1050PB	Pacific Blue
1050BW	Bone White	1050PG	Patina Green
1050CG	Charcoal Gray	1050RB	Royal Blue
1050CR	Colonial Red	1050SB	Slate Blue
1050DB	Dark Bronze	1050SG	Slate Gray
1050DG	Dove Gray	1050SS	Sandstone
1050DR	Deep Red	1050ST	Sierra Tan
1050EM	Everglade Moss	1050SW	Stone White
1050FG	Forest Green	1050SN	SunNet Blue
1050HG	Hartford Green	1050TC	Terracotta
1050HL	Hemlock Green	1050MC	Metallic Copper
1050MA	Mansard Brown	1050CH	Champagne
1050MB	Medium Bronze	1050PW	Prewathered Galvalume
1050MT	Matte Black	00826A	Mill Finish

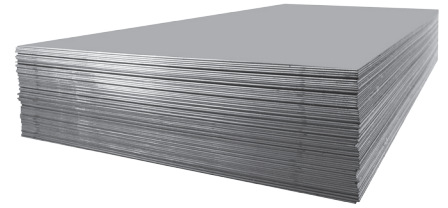

SPECIFICATIONS:

- 25 sheets to a skid.
- Sheets come standard with strippable clear film.
- Storage of sheets, see page 39.
- **CAUTION!** Metallic Copper, Champagne and Prewathered Galvalume are directional paints. (Aesthetics for Mill Finish products are not guaranteed.)

Aluminum Sheets 4 x 10 x .063

#3105-H24 Alloy / Kynar 500 Finish – Standard, Non-Stocking

PART NO.	COLOR	PART NO.	COLOR
1063BD	Burgundy	1063PB	Pacific Blue
1063BW	Bone White	1063PG	Patina Green
1063CG	Charcoal Gray	1063RB	Royal Blue
1063CR	Colonial Red	1063SB	Slate Blue
1063DB	Dark Bronze	1063SG	Slate Gray
1063DG	Dove Gray	1063SS	Sandstone
1063DR	Deep Red	1063ST	Sierra Tan
1063EM	Everglade Moss	1063SW	Stone White
1063FG	Forest Green	1063SN	SunNet Blue
1063HG	Hartford Green	1063TC	Terracotta
1063HL	Hemlock Green	1063MC	Metallic Copper
1063MA	Mansard Brown	1063CH	Champagne
1063MB	Medium Bronze	1063PW	Prewathered Galvalume
1063MT	Matte Black	1063MF	Mill Finish

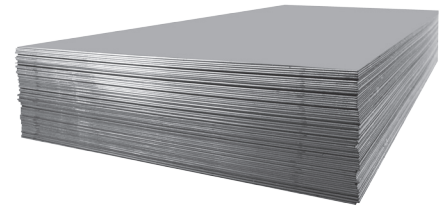

SPECIFICATIONS:

- 25 sheets to a skid.
- Sheets come standard with strippable clear film.
- Storage of sheets, see page 39.
- **CAUTION!** Metallic Copper, Champagne and Prewathered Galvalume are directional paints. (Aesthetics for Mill Finish products are not guaranteed.)

Copper Sheets

PART NO.	DESCRIPTION	AVAILABILITY
06203M	3 x 10 x 16 oz	Stock

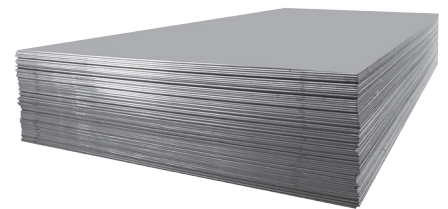

SPECIFICATIONS:

- 65 sheets to a skid.
- 20 oz available through special request.
- Storage of sheets, see page 39. (Aesthetics for Mill Finish products are not guaranteed.)

* Minimum ordering quantities may apply. Please consult with an Englert representative before ordering. Specifications subject to change without notice.



Copper Coil

PART NO.	DESCRIPTION	AVAILABILITY
00677A	20" x 16 oz	Stock
00677L	24" x 16 oz	Stock

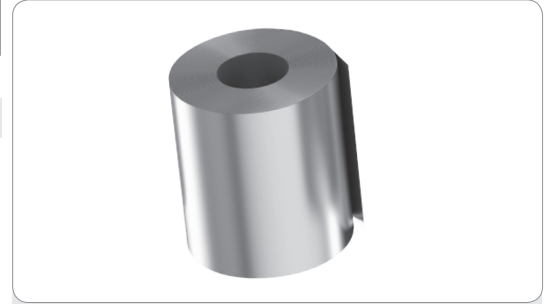

SPECIFICATIONS:

- Coil ID: 20"
- Coils range from 500 - 1000 LBS. (Aesthetics for Mill Finish products are not guaranteed.)

Zinc Sheets 39.4" x 10' .7mm/.8mm

PART NO.	DESCRIPTION	AVAILABILITY
ORZ0441	.7mm (24 gauge) Preweathered Blue-Grey	Stock
ORZ0461	.8mm (22 gauge) Preweathered Blue-Grey	Stock

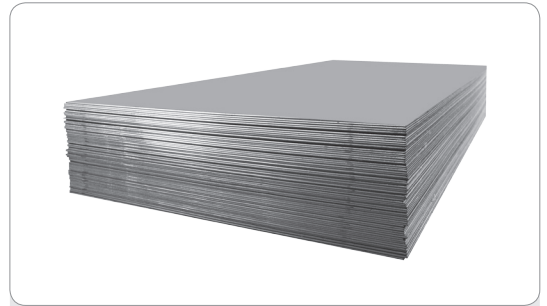

SPECIFICATIONS:

- 25 sheets to a skid.
- Graphite Grey available through special request.
- Storage of sheets, see page 39. (Aesthetics for Mill Finish products are not guaranteed.)

Zinc Coil .7mm/.8mm

PART NO.	DESCRIPTION	AVAILABILITY
ORZ0442	39.4" x .7mm (24 gauge) Preweathered Blue-Grey	Stock
ORZ0451	19.7" x .7mm (24 gauge) Preweathered Blue-Grey	Stock
ORZ0462	39.4" x .8mm (22 gauge) Preweathered Blue-Grey	Stock
ORZ0471	19.7" x .8mm (22 gauge) Preweathered Blue-Grey	Stock



SPECIFICATIONS:

- Coil ID: 20"
- Approximate coil size 1100 LBS.
- Graphite Grey available through special request. (Aesthetics for Mill Finish products are not guaranteed.)

* Minimum ordering quantities may apply. Please consult with an Englert representative before ordering. Specifications subject to change without notice.

Englert E-375 Commercial Soffit Panel & J Channel

PART NO.	DESCRIPTION	BOX QUANTITY	AVAILABILITY
0038BW	.032" Soffit Panel/Bone White (Solid Face) (Aluminum)	12 pc. at 12'-0"	2-4 Weeks
0037BW	.032" Soffit Panel/Bone White (Perforated) (Aluminum)	12 pc. at 12'-0"	2-4 Weeks
0059BW	.032" x 3/8" J Channel (Aluminum)	25 pc. at 12'-0"	2-4 Weeks

Other lengths, colors and materials available by special quote. See your local Englert representative for info.

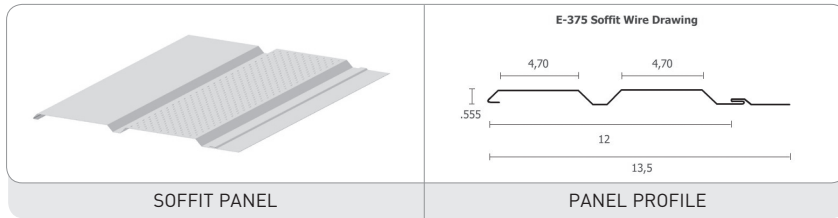

EDGE METAL AND SOFFIT

Edge Metal

PART NO.	DESCRIPTION	COLOR	FT/BOX	AVAILABILITY
00278H	Standard Asphalt Drip Edge (Fascia cap 4" x 10')	Bright White	500	Stock
00278I	Standard Asphalt Drip Edge (Fascia cap 4" x 10')	Brown	500	Stock
00278D	Gravel Stop (5.75" x 10')	Bright White	120	Stock
00278E	Gravel Stop (5.75" x 10')	Brown	120	Stock
00278F	T Style Drip Edge (5.78" x 10')	Bright White	120	Stock
00278G	T Style Drip Edge (5.78" x 10')	Brown	120	Stock
00278B	Gutter Apron 6 Inch Drip Edge (6" x 10')	Bright White	300	Stock
00278C	Gutter Apron 6 Inch Drip Edge (6" x 10')	Brown	300	Stock
00279B	Gutter Apron 4.5 Inch Drip Edge (4.5" x 10')	Bright White	300	Stock
00279C	Gutter Apron 4.5 Inch Drip Edge (4.5" x 10')	Brown	300	Stock

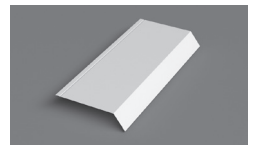
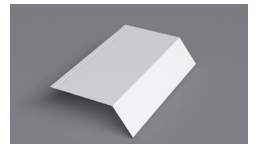
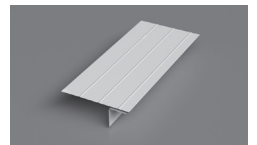
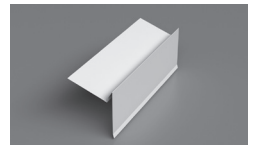
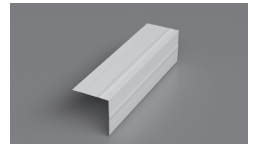

* Minimum ordering quantities may apply. Please consult with an Englert representative before ordering. Specifications subject to change without notice.

About Clip Spacing...

This guide is intended to provide you with sufficient information so that you may choose the appropriate clip for our metal roof system. We have purposely omitted any reference to clip spacing as this element of roof design varies by panel width, panel material, seam style, substrate your fastening to, and building codes in the area your job is located. For more specific guidance on appropriate clip spacing for your particular job contact Englert for assistance at 1-800-610-1975.

Series 1000

PART NO.	DESCRIPTION	RATINGS	BOX QUANTITY	AVAILABILITY
05074B	R Clip 1000 Universal, 24 Gauge Galvalume	UL	800 pcs.	Stock
05074C	R Clip 1000 Universal, 24 Gauge Stainless Steel	Not Rated	800 pcs.	4-6 Weeks

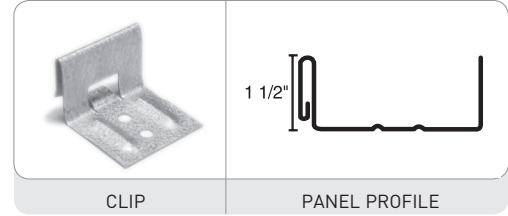

Series 1100

PART NO.	DESCRIPTION	RATINGS	BOX QUANTITY	AVAILABILITY
05079A	R Clip 1100 Universal, 24 Gauge Galvalume	UL	400	Stock
05079F	R Clip 1100 Universal, 24 Gauge Stainless Steel	Not Rated	400	4-6 Weeks

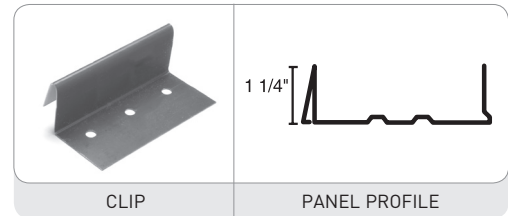

Series 1300

PART NO.	DESCRIPTION	RATINGS	BOX QUANTITY	AVAILABILITY
05845A	R Clip 1300 Floating, .015" Stainless Steel	Not Rated	250	Stock
05815A	R Clip 1300 Floating, .030" Stainless Steel	Florida Building Code Listed	250	Stock

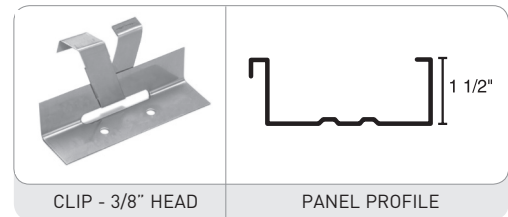

(For use with Englert, New Tech, Rollformer & ESE Panel Shapes)

NOTE: These clips are designed for use with Englert Series Metal Roofing Systems. If you are using a similar profile and have not used our clips before, we encourage you to request a sample to check for fit before you place an order. **Contact your Englert sales representative for a sample today!**

* Minimum ordering quantities may apply. Please consult with an Englert representative before ordering. Specifications subject to change without notice.

Series 1300

PART NO.	DESCRIPTION	RATINGS	BOX QUANTITY	AVAILABILITY
05855A	R Clip 1300 Floating, .015" Stainless Steel	Not Rated	250	Stock

(For use with Knudson Panel Shapes)

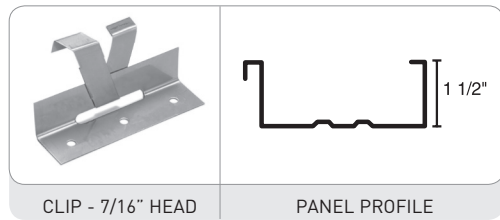

Series 1300

PART NO.	DESCRIPTION	RATINGS	BOX QUANTITY	AVAILABILITY
05084D	R Clip 1300 Fixed, 24 Gauge Galvalume	UL/Florida Building Code Listed	250	Stock
05084E	R Clip 1300 Fixed, 24 Gauge Stainless Steel	Not Rated	250	Stock

(For use with Englert, New Tech, Rollformer & ESE Panel Shapes)

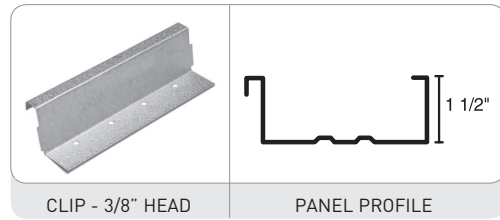

Series 1300

PART NO.	DESCRIPTION	RATINGS	BOX QUANTITY	AVAILABILITY
05874A	R Clip 1300 Fixed, .018" Galvalume	Not Rated	800	Stock
05835A	R Clip 1300 Fixed, .015" Stainless Steel	Not Rated	800	Stock

(For use with Englert, New Tech, Rollformer & ESE Panel Shapes)

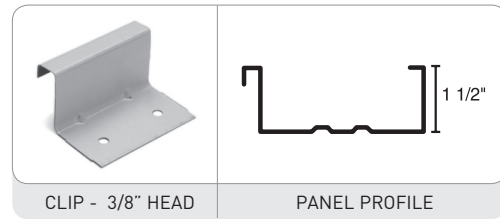

Series 1300

PART NO.	DESCRIPTION	RATINGS	BOX QUANTITY	AVAILABILITY
05872A	R Clip 1300 Fixed, .018" Galvalume	Florida Building Code Listed	800	Stock
05837A	R Clip 1300 Fixed, .015" Stainless Steel	Not Rated	800	Stock

(For use with Knudson Panel Shapes)

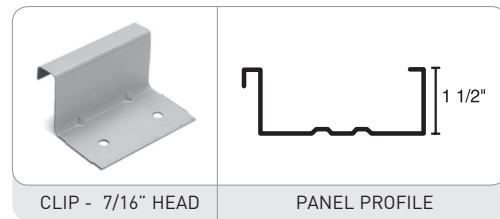

Series 1300

PART NO.	DESCRIPTION	RATINGS	BOX QUANTITY	AVAILABILITY
05828J	R Clip 1300 Fixed, 24 Gauge Galvalume 3"	Florida Building Code Listed	500	4-6 Weeks

(For use with Zimmerman, Knudson, Schleich & Rollformer Panel Shapes)

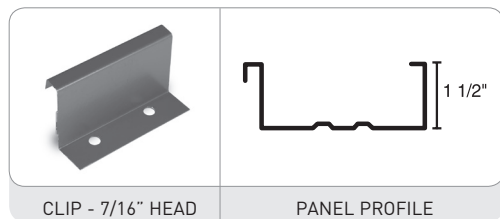

NOTE: These clips are designed for use with Englert Series Metal Roofing Systems. If you are using a similar profile and have not used our clips before, we encourage you to request a sample to check for fit before you place an order. **Contact your Englert sales representative for a sample today!**



* Minimum ordering quantities may apply. Please consult with an Englert representative before ordering. Specifications subject to change without notice.

Series 1301

PART NO.	DESCRIPTION	RATINGS	BOX QUANTITY	AVAILABILITY
05839A	R Clip 1301 Floating, .015" Stainless Steel	Not Rated	250	Stock
05839B	R Clip 1301 Floating, .030" Stainless Steel	Not Rated	250	4-6 Weeks

(For use with Englert, New Tech, Rollformer & ESE Panel Shapes)

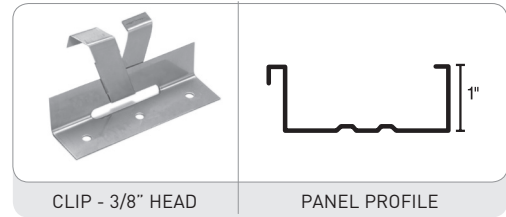

Series 1301

PART NO.	DESCRIPTION	RATINGS	BOX QUANTITY	AVAILABILITY
05875A	R Clip 1301 Fixed, .018" Galvalume	Not Rated	800	Stock
05833A	R Clip 1301 Fixed, .015" Stainless Steel	Not Rated	800	Stock

(For use with Englert, New Tech, Rollformer & ESE Panel Shapes)

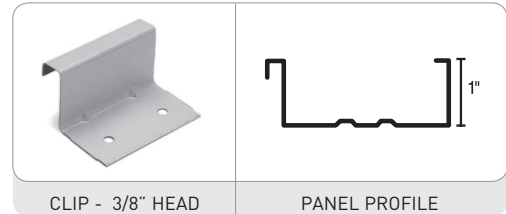

Series 1500

PART NO.	DESCRIPTION	RATINGS	BOX QUANTITY	AVAILABILITY
05828H	R Clip 1500 20 Gauge Galvanized	Not Rated	500	Stock
SP5999	R Clip 1500 18 Gauge Galvanized	UL/Florida Building Code Listed	250	4-6 Weeks

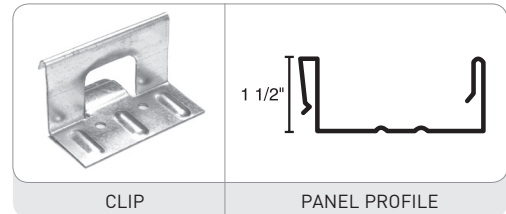

Series 2000

PART NO.	DESCRIPTION	RATINGS	BOX QUANTITY	AVAILABILITY
05079B	R Clip 2000 Butterfly Batten, 24 Gauge Stainless Steel	Not Rated	400	Stock

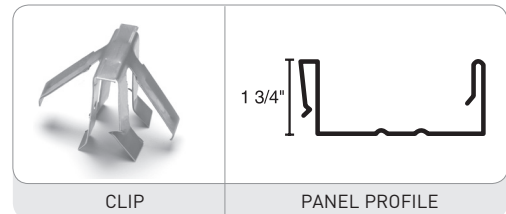

Series 2000

PART NO.	DESCRIPTION	RATINGS	BOX QUANTITY	AVAILABILITY
05076B	R Clip 2000 Universal, 18 Gauge Galvanized	UL	200	Stock
05076D	R Clip 2000 Universal, 18 Gauge Stainless Steel	Not Rated	200	4-6 Weeks

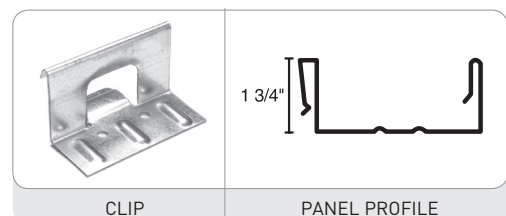

NOTE: These clips are designed for use with Englert Series Metal Roofing Systems. If you are using a similar profile and have not used our clips before, we encourage you to request a sample to check for fit before you place an order. **Contact your Englert sales representative for a sample today!**

* Minimum ordering quantities may apply. Please consult with an Englert representative before ordering. Specifications subject to change without notice.

Series 2000

PART NO.	DESCRIPTION	RATINGS	BOX QUANTITY	AVAILABILITY
05076C	R Clip 2000 Universal, 18 Gauge Galvanized	Not Rated	400	Stock
05077B	R Clip 2000 Universal, 20 Gauge Stainless Steel	Not Rated	400	4-6 Weeks

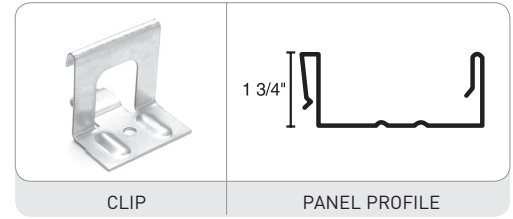

CLIP

PANEL PROFILE

Series 2000 Base Plate

PART NO.	DESCRIPTION	RATINGS	BOX QUANTITY	AVAILABILITY
05075C	R BASE 2000 Bearing Plate, 24 Gauge Galvalume	Not Rated	200	Stock

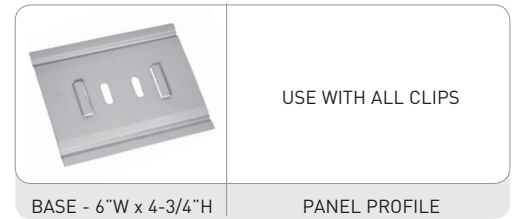

BASE - 6"W x 4-3/4"H

PANEL PROFILE

Universal Base Plate - All Clips

PART NO.	DESCRIPTION	RATINGS	BOX QUANTITY	AVAILABILITY
05075F	R BASE Universal, 24 Gauge Galvalume	Not Rated	200	Stock

Universal base can be used with any clip over ISO board insulation

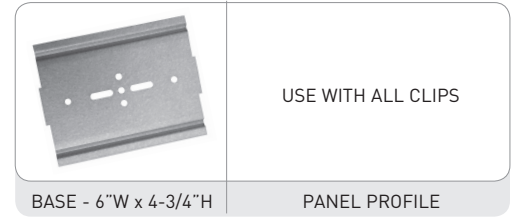

BASE - 6"W x 4-3/4"H

PANEL PROFILE

Series 2400

PART NO.	DESCRIPTION	RATINGS	BOX QUANTITY	AVAILABILITY
05890I	R Clip 2400 Fixed, 24 Gauge Galvalume	Not Rated	250	Stock
05890H	R Clip 2400 Fixed, 22 Gauge Galvalume	Not Rated	250	2-4 Weeks

(Can also be used with Series 2500 Profile), (OK for Double Lock Seams)

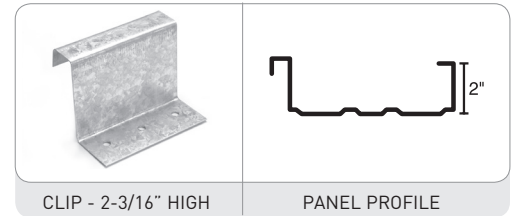

CLIP - 2-3/16" HIGH

PANEL PROFILE

Series 2500 Low Float

PART NO.	DESCRIPTION	RATINGS	BOX QUANTITY	AVAILABILITY
05082F	R Clip 2500 Low Floating, 22 Gauge Galvanized	UL	100	Stock

(Can also be used with Series 2400 Profile), (Not available in Stainless Steel), (Not for Double Lock Seams)

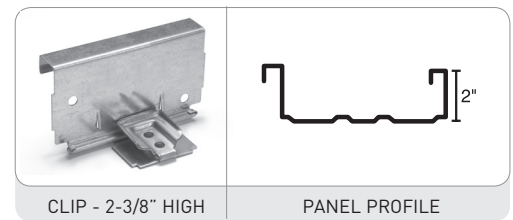

CLIP - 2-3/8" HIGH

PANEL PROFILE

NOTE: These clips are designed for use with Englert Series Metal Roofing Systems. If you are using a similar profile and have not used our clips before, we encourage you to request a sample to check for fit before you place an order. **Contact your Englert sales representative for a sample today!**



* Minimum ordering quantities may apply. Please consult with an Englert representative before ordering. Specifications subject to change without notice.

Series 2500 High Float

PART NO.	DESCRIPTION	RATINGS	BOX QUANTITY	AVAILABILITY
05082C	R Clip 2500 High Floating, 22 Gauge Galvanized	UL	100	2-4 Weeks

(Can also be used with Series 2400 Profile), (Not available in Stainless Steel), (Not for Double Lock Seams)

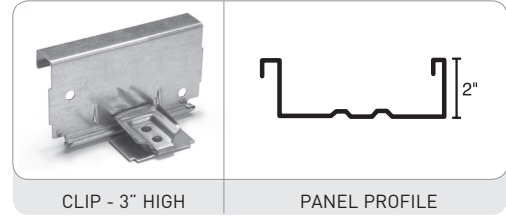

CLIP - 3" HIGH

PANEL PROFILE

Series 2500

PART NO.	DESCRIPTION	RATINGS	BOX QUANTITY	AVAILABILITY
05083A	R Clip 2500 Fixed, Utility 22 Gauge Galvanized	Not Rated	400	2-4 Weeks

(Can also be used with Series 2400 Profile), (Not available in Stainless Steel), (OK for Double Lock Seams)

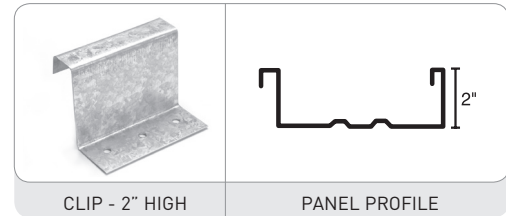

CLIP - 2" HIGH

PANEL PROFILE

Series 2500

PART NO.	DESCRIPTION	RATINGS	BOX QUANTITY	AVAILABILITY
05081B	R Clip 2500 Low Fixed, 22 Gauge Galvanized	UL	250	2-4 Weeks

(Can also be used with Series 2400 Profile), (Not available in Stainless Steel), (Not for Double Lock Seams)

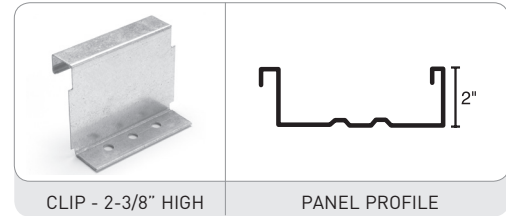

CLIP - 2-3/8" HIGH

PANEL PROFILE

Series 2500

PART NO.	DESCRIPTION	RATINGS	BOX QUANTITY	AVAILABILITY
05081C	R Clip 2500 High Fixed, 22 Gauge Galvanized	UL	250	2-4 Weeks

(Can also be used with Series 2400 Profile), (Not available in Stainless Steel), (Not for Double Lock Seams)

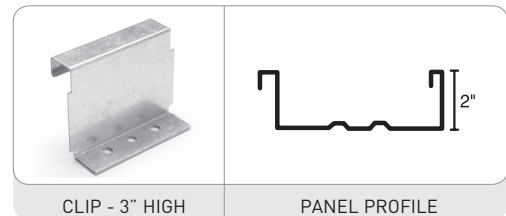

CLIP - 3" HIGH

PANEL PROFILE

NOTE: These clips are designed for use with Englert Series Metal Roofing Systems. If you are using a similar profile and have not used our clips before, we encourage you to request a sample to check for fit before you place an order. **Contact your Englert sales representative for a sample today!**

* Minimum ordering quantities may apply. Please consult with an Englert representative before ordering. Specifications subject to change without notice.

Series 2500/Series 2516 FM Approved

PART NO.	DESCRIPTION	RATINGS	BOX QUANTITY	AVAILABILITY
05082H	R Clip 2500/2516 Floating Top, 24 Gauge Stainless Steel	FM 90*	250	Stock
05082J	R Clip 2500/2516 Floating Top, 24 Gauge Galvalume	FM 75*	250	4-6 Weeks

* Only Series 2516 is FM Approved (Use with 05082I), (OK for Double Lock Seams)

PART NO.	DESCRIPTION	RATINGS	BOX QUANTITY	AVAILABILITY
05082I	R Clip 2500/2516 Floating Base, 18 Gauge Galvanized	FM 75/90*	500	Stock
05082K	R Clip 2500 Floating Base, 18 Gauge Stainless Steel	Not Rated	500	4-6 Weeks

* Only Series 2516 is FM Approved (Use with 05082H or 05082J), (OK for Double Lock Seams)

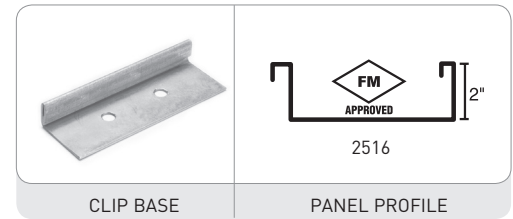
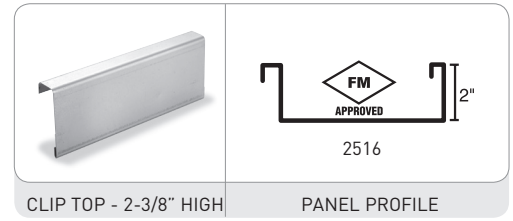

Series 3000

PART NO.	DESCRIPTION	RATINGS	BOX QUANTITY	AVAILABILITY
05085A	R Clip 3000 Fixed, .060" Galvanized	Not Rated	150	Stock
05085E	R Clip 3000 Fixed, .060" Stainless Steel	Not Rated	150	4-6 weeks

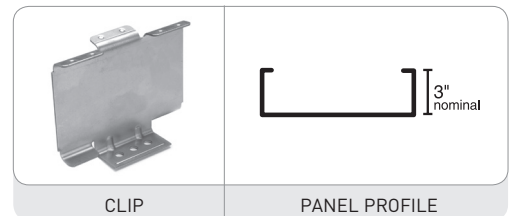

Series 3000/Series 3016 FM Approved

PART NO.	DESCRIPTION	RATINGS	BOX QUANTITY	AVAILABILITY
05085C	R Clip 3000/3016 Floating, .060" Galvanized	FM Rated*	100	4-6 Weeks
05085B	R Clip 3000 Floating Top, .060" Stainless Steel	Not Rated	100	4-6 Weeks

* Only Series 3016 is FM Approved

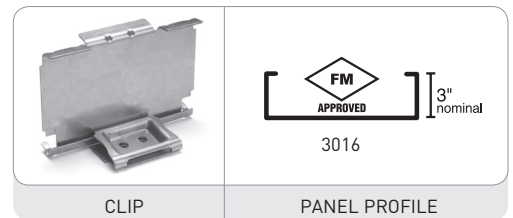

NOTE: These clips are designed for use with Englert Series Metal Roofing Systems. If you are using a similar profile and have not used our clips before, we encourage you to request a sample to check for fit before you place an order. **Contact your Englert sales representative for a sample today!**



* Minimum ordering quantities may apply. Please consult with an Englert representative before ordering. Specifications subject to change without notice.

Concealor Low Profile Clip Fasteners GP

PART NO.	DESCRIPTION	BOX QUANTITY	AVAILABILITY
06041C	#10-12 X 1"	5,000	Stock
06042E	#10-13 X 1"	5,000	Stock
OPK02C	#10-13 X 1-1/2"	3,000	2-4 Weeks
OPK03C	#10-13 X 2"	2,000	2-4 Weeks

Application: Panel Clip To Wood, Wood Substrates

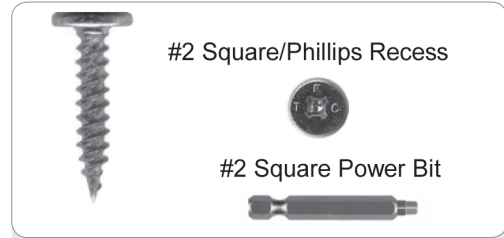

SPECIFICATIONS:

- Pancake Head Clip Fastener
- Carbon Steel - Zinc and Yellow

Concealor Low Profile Clip Fasteners DP

PART NO.	DESCRIPTION	BOX QUANTITY	AVAILABILITY
06041B	#10-16 X 1"	5,000	Stock

Application: Clip To Metal Metal Substrates <12 gauge



SPECIFICATIONS:

- Pancake Head Clip Fastener
- Carbon Steel - Zinc and Yellow

Concealor Low Profile Clip Fasteners GP

PART NO.	DESCRIPTION	BOX QUANTITY	AVAILABILITY
OPK01S	#10-13 X 1" Stainless Steel	5,000	2-4 Weeks
OPK02S	#10-13 X 1-1/2" Stainless Steel	3,000	2-4 Weeks

Application: Panel Clip Screw (SS & CU) Wood Substrates

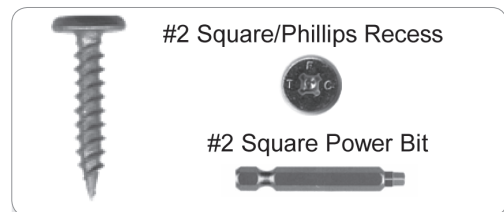

SPECIFICATIONS:

- Pancake Head Clip Fastener
- 304 Stainless Steel - Passivated

Concealor Low Profile Clip Fasteners DP3

PART NO.	DESCRIPTION	BOX QUANTITY	AVAILABILITY
OPK03S	#10-16 X 1" Stainless Steel	5,000	2-4 Weeks

Application: Panel Clip Screw (SS & CU) Metal <14 gauge

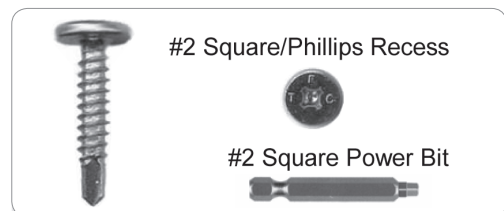

SPECIFICATIONS:

- Pancake Head Clip Fastener
- 410 Stainless Steel - Zinc Plated

* Minimum ordering quantities may apply. Please consult with an Englert representative before ordering. Specifications subject to change without notice.

Concealor Low Profile Clip Fasteners ULP

PART NO.	DESCRIPTION	APPLICATION	BOX QTY.	AVAILABILITY
OPK04C	#10-9 X 1-1/8" Carbon Steel	Panel Clip to Wood Clip <20 gauge to Wood Substrates	5,000	2-4 Weeks
06040T	#10-9 X 1-1/8" Gimlet Point	Panel Clip to Wood Clip <20 gauge to Wood Substrates	5,000	Stock

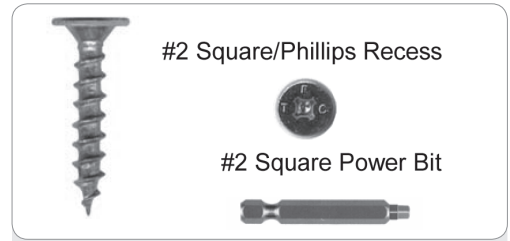

SPECIFICATIONS:

- Ultra Low Profile Pancake Head Clip Fastener

Concealor Low Profile Clip Fasteners

Carbon Steel - Epoxy Coated

Part No.	Size	Insulation Thickness/Attachment Range		Box Qty.	Availability
		Wood Allows 1" Penetration into Wood	Metal >16ga Allows 1/2" Penetration into Metal		
OPK1EC	#14-13 x 1-1/2" DP1	<1"	<1"	2,500	2-4 Weeks
OPK2EC	#14-13 x 2" DP1	<1-1/2"	<1-1/2"	1,000	2-4 Weeks
OPK3EC	#14-13 x 3" DP1	<2"	<2"	1,000	2-4 Weeks
OPK4EC	#14-13 x 4" DP1	1/2" to 3"	1/2" to 3-1/2"	1,000	2-4 Weeks
OPK5EC	#14-13 x 4-1/2" DP1	1" to 3-1/2"	1" to 4"	1,000	2-4 Weeks
OPK6EC	#14-13 x 5" DP1	1-1/2" to 4"	1-1/2" to 4-1/2"	1,000	2-4 Weeks
OPK7EC	#14-13 x 6" DP1	2-1/2" to 5"	2-1/2" to 5-1/2"	1,000	2-4 Weeks
OPK8EC	#14-13 x 7" DP1	3-1/2" to 6"	3-1/2" to 6-1/2"	500	2-4 Weeks

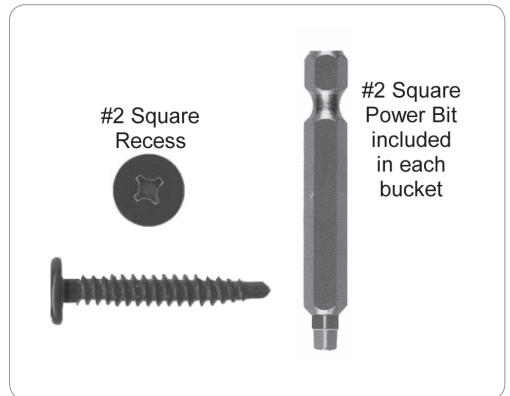

* Minimum ordering quantities may apply. Please consult with an Englert representative before ordering. Specifications subject to change without notice.

DP2 (Panel to Steel Frame Attachment Screw)

PART NO.	DESCRIPTION	FINISH	BOX QTY.	AVAILABILITY
OPK01M	#12-14 X 1-1/4"	Mill	2,500	2-4 Weeks
OPK1*	#12-14 X 1-1/4"	Painted	2,500	2-4 Weeks

Application: Through Fastening into Metal Structure



SPECIFICATIONS:

- Blazer Self-Drill
- 5/16" Zinc Head
- Warranted Roof System

*Please specify color.
Available in Englert Standard Colors.

DP1/LAP (Stitch Screw)

PART NO.	DESCRIPTION	FINISH	BOX QTY.	AVAILABILITY
OPK02M	#1/4-14 X 7/8"	Mill	2,500	2-4 Weeks
OPK2*	#1/4-14 X 7/8"	Painted	2,500	2-4 Weeks

Application: Through Fastening into Panel Laps



SPECIFICATIONS:

- Blazer Self-Drill
- 5/16" Zinc Head
- Warranted Roof System

*Please specify color.
Available in Englert Standard Colors.

#10 Gimlet Point (Panel to Wood Frame Attachment Screw)

PART NO.	DESCRIPTION	FINISH	BOX QTY.	AVAILABILITY
OPK03M	#10-15 X 1"	Mill	2,500	2-4 Weeks
OPK3*	#10-15 X 1"	Painted	2,500	2-4 Weeks
OPK04M	#10-15 X 1-1/2"	Mill	2,500	2-4 Weeks
OPK4*	#10-15 X 1-1/2"	Painted	2,500	2-4 Weeks
OPK05M	#10-15 X 2"	Mill	2,500	2-4 Weeks
OPK5*	#10-15 X 2"	Painted	2,500	2-4 Weeks

Application: Through Fastening into Wood Structure



SPECIFICATIONS:

- Panel-Tite Post
- Frame Fastener
- 5/16" Zinc Head
- Warranted Roof System

*Please specify color.
Available in Englert Standard Colors.

#12 Gimlet Point (Panel to Wood Frame Attachment Screw)

PART NO.	DESCRIPTION	FINISH	BOX QTY.	AVAILABILITY
OPK06M	#12-14 X 3/4"	Mill	2,500	2-4 Weeks
OPK6*	#12-14 X 3/4"	Painted	2,500	2-4 Weeks

Application: Through Fastening into Wood Structure



SPECIFICATIONS:

- Panel-Tite Post
- Frame Fastener
- 5/16" Zinc Head
- Warranted Roof System

*Please specify color.
Available in Englert Standard Colors.

* Minimum ordering quantities may apply. Please consult with an Englert representative before ordering. Specifications subject to change without notice.

Rivets

PART NO.	SIZE/ DESCRIPTION	APPLICATION	BOX QTY.	AVAIL.
OPKS*	1/8" dia. x 1/4", Grip Rivet (#44) Stainless Steel Body and Mandrel Painted Englert Standard Colors	Painted Stainless Pop Rivet Exposed Metal to Metal	1,000	2-4 Weeks
OPKRS1	1/8" dia. x 1/4", Grip Rivet (#44) Stainless Steel Body and Mandrel Mill Finish	Stainless Pop Rivet Concealed Metal to Metal	1,000	2-4 Weeks
OPKRC1	1/8" dia. x 1/4", Grip Rivet (#42) Copper Body and Mandrel Mill Finish	Copper Pop Rivet Copper Metal to Metal	1,000	2-4 Weeks
OPKRA1	1/8" dia. x 1/4", Grip Rivet (#44) Aluminum Body and Mandrel Mill Finish	Aluminum Pop Rivet Aluminum or Steel Metal to Metal	1,000	2-4 Weeks
OPKA*	1/8" dia. x 1/4", Grip Rivet (#42) Aluminum Body and Mandrel Mill Finish Englert Standard Colors	Painted Aluminum Pop Rivet Aluminum or Steel Metal to Metal	1,000	2-4 Weeks
00262*	1/8" dia. x 3/8", Grip Rivet (#44) Stainless Steel Body and Mandrel Painted Englert Standard Colors		250/Bag	Stock

Use #30 Drill Bit



*Please specify color.

Cor-A-Vent

PART NO.	DESCRIPTION	BOX QUANTITY	AVAILABILITY
OPKVNT	Ridge Vent (V600) 11" x 4'	12 Pcs.	2-4 Weeks
OPKVNT4	Ridge Vent (V600E) 11" x 4'	12 Pcs.	2-4 Weeks
OPKVNT2	Ridge Vent (V600T) 3-1/4" x 4'	24 Pcs.	2-4 Weeks

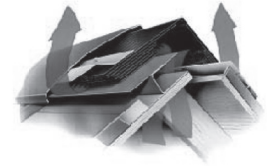

Butyl Tape

PART NO.	SIZE/ DESCRIPTION	BOX QUANTITY	AVAILABILITY
00320E	Sealer Tape 1/8" x 1" x 40' Roll	12 Rolls	Stock



*Please specify color.

* Minimum ordering quantities may apply. Please consult with an Englert representative before ordering. Specifications subject to change without notice.



Englert - Kynar Touch Up Paint

CAUTION! Only use Englert Kynar based Touch Up Paint for repair of small nicks and scratches. Areas requiring extensive repair can only be refinished by a professional. Contact your Englert branch for ordering information.

PART NO.	DESCRIPTION	AVAILABILITY
0028*	2 Ounce Container	Stock



*Please specify color.

Pipe/Boot Flashing

Pipe Master EPDM and High Temp Silicone

PART NO.	SIZE	PIPE O.D.	BOX QTY.	AVAILABILITY
OPKPF1	#1	1/4" to 2"	15	2-4 Weeks
OPKPF2	#2	1-3/4" to 3-1/4"	15	2-4 Weeks
OPKPF3	#3	1/4" to 4"	15	2-4 Weeks
OPKPF4	#4	3" to 6"	10	2-4 Weeks
OPKPF5	#5	4" to 7"	10	2-4 Weeks
OPKPF6	#6	5" to 9"	10	2-4 Weeks
OPKPF7	#7	6" to 11"	10	2-4 Weeks
OPKPF8	#8	8" to 13"	5	2-4 Weeks
OPKPF9	#9	10" to 18"	5	2-4 Weeks
OPKPS3	Silicone #3	1/4" to 4"	15	2-4 Weeks
OPKPS5	Silicone #5	4" to 7"	10	2-4 Weeks
OPKPS8	Silicone #8	8" to 13"	5	2-4 Weeks
OPKPS9	Silicone #9	10" to 18"	5	2-4 Weeks

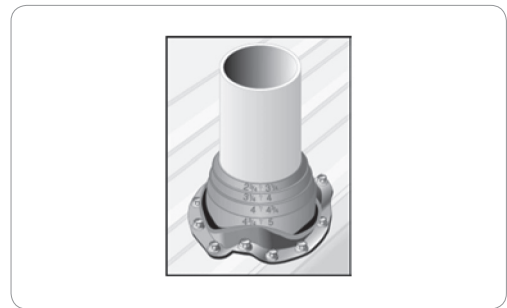

Pipe/Boot Flashing - Pipe Master RM

Roof Match Colored Pipe Flashing, 8 Colors

PART NO.	SIZE	PIPE O.D.	BOX QTY.	AVAILABILITY
06059D**	#3RM	1/4" to 5"	15	Stock
OPK3RM*	#3RM	1/4" to 5"	15	2-4 Weeks
OPK5RM*	#5RM	4.25" to 7.75"	10	2-4 Weeks
OPK7RM*	#7RM	6" to 11"	10	2-4 Weeks

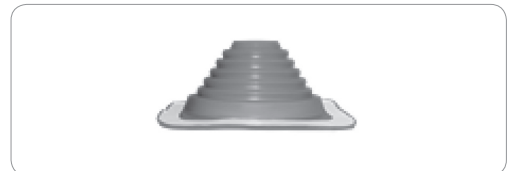

* Please specify color.
** Only available in grey.

Pipe/Boot Flashing - Wraparound for Retrofit Applications

PART NO.	SIZE	PIPE O.D.	BOX QTY.	AVAILABILITY
OPKR01	Retro 801	1/2" to 4"	10	2-4 Weeks
OPKR02	Retro 802	4" to 9-1/4"	5	2-4 Weeks
OPKR03	Retro 803	9-1/4" to 16-1/4"	5	2-4 Weeks

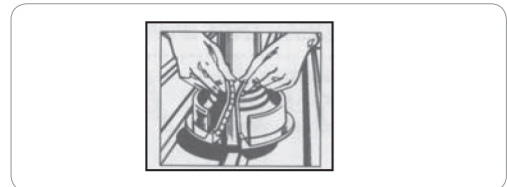

* Minimum ordering quantities may apply. Please consult with an Englert representative before ordering. Specifications subject to change without notice.

Englert Approved -

Tube Sealants

PART NO.	COLOR	DESCRIPTION	TUBE SIZE	BOX QTY.	AVAILABILITY
00319A	Clear	Geocel 2300 Tripolymer	10.3 oz.	24	Stock

Englert standard colors are available, but require minimum order.
Please contact your local Englert sales representative for details.



00319C	White	Geocel 2320 Tripolymer	10.3 oz.	24	Stock
--------	-------	------------------------	----------	----	-------

Englert standard colors are available, but require minimum order.
Please contact your local Englert sales representative for details.

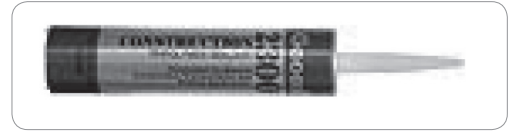

Englert Approved -

High Temperature Peel and Stick Roofing Underlayment

PART NO.	DESCRIPTION	ROLL QTY.	AVAILABILITY
07050I	MetalMan HT 40 (40 mil Peel & Stick Membrane)	200 Sq. Ft.	Stock
07050P	MetalMan HT 60 (60 mil Peel & Stick Membrane)	200 Sq. Ft.	Stock

- FBC Approved



Englert Approved -

Roofing Underlayment Nail Down Vapor Barrier

PART NO.	DESCRIPTION	ROLL QTY.	AVAILABILITY
07050J	Premium Nailable Underlayment (48" x 250')	1,000 Sq. Ft.	Stock

- Required for Englert Weathertightness Warranty
- FBC Approved/Miami Dade Approved
- Synthetic Membrane - ASTM-D-226 Compliant



Englert Approved -

Hot Melt Seam Sealant for Metal Roof Rollforming

PART NO.	DESCRIPTION	UNIT	WT.	AVAILABILITY
00320H	Pillows - HMT 3308-P	1 Box	25 Lbs.	Stock

To be used with HMT-Proflex Unit in conjunction with your rollforming equipment

- 400 Lineal Ft/Lb at 1/8" Bead



MetalMan Fixed Panel Roofing Machine

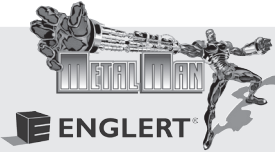

MetalMan Fixed Panel Roofing Machine

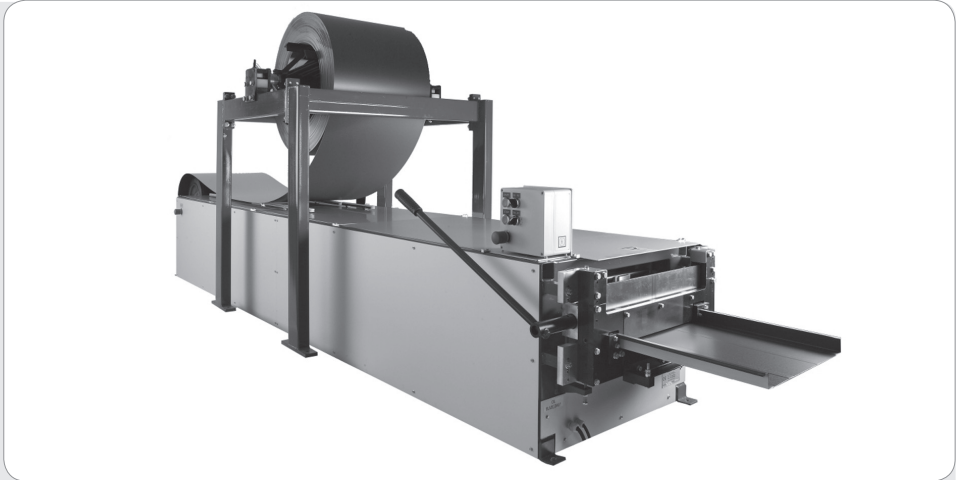

Englert Inc. brings in-plant manufacturing to the job site with a complete line of Fixed Panel (FP) Roll Forming Machines. These state-of-the-art portable roll forming machines will run single size panels in various gauges and types of materials with minimum adjustment and less scrap. On-site fabrication with the MetalMan FP Series Machine results in greater job control, eliminating shipping damage, short shipments and many sizing errors while providing packaging and freight savings. These durable machines are the ideal choice for roofing companies seeking unmatched quality and performance at affordable prices.

FEATURES:

- Separate drive roller systems designed to eliminate most oil canning
- Polyurethane drive rollers
- Chrome plated forming roller system
- Dual emergency stop switches at entry and exit ends of machines
- Easy to operate hand shear
- Two pairs of 1 inch adjustable flat rib rollers
- One 3000 lb. capacity expandable arbor with stand
- Clip relief rollers - standard
- Run out limit switch - standard

AVAILABLE OPTIONS:

- Dual 3000 lb. capacity expandable arbors and stand
- 10' sections of variable height run out stands
- Hand seamers 1300/1301
- Electric seamers 1300/1301
- 12000 lb. capacity tandem axle trailer (part no. 01640TA)
- Pencil ribs 3/8" or 5/8" and frame
- Striation rollers and frame

Specifications subject to change without notice.

1.800.610.1975 www.englertinc.com

MetalMan Fixed Panel Roofing Machines

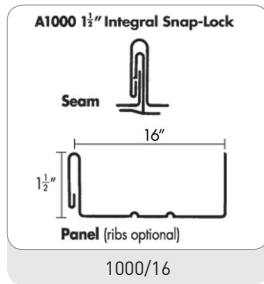

1000/16

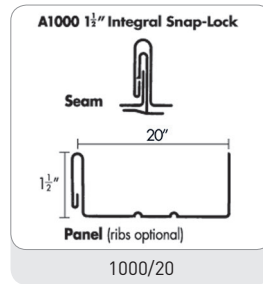

1000/20

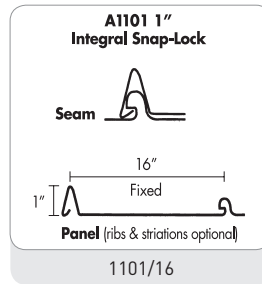

1101/16

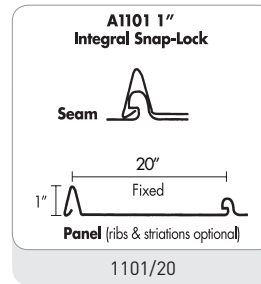

1101/20

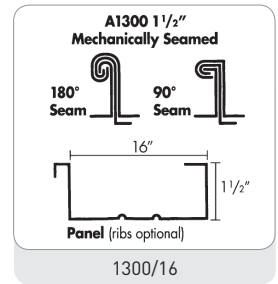

1300/16

METALMAN ROOFING MACHINES

FP 1000/16

Runs a fixed width, variable length, single-profile 1.5 in. (38.1 mm) high x .25 in. (6.4 mm) wide snap-lock panel configuration with a 16 in. (406.4 mm) coverage.

FP 1000/20

Runs a fixed width, variable length, single-profile 1.5 in. (38.1 mm) high x .25 in. (6.4 mm) wide snap-lock panel configuration with a 20 in. (508 mm) coverage.

FP 1101/16

Runs a fixed width, variable length, single-profile 1 in. (38.1 mm) high, nail strip snap-lock panel configuration with a 16 in. (406.4 mm) coverage.

FP 1101/20

Runs a fixed width, variable length, single-profile 1 in. (38.1 mm) high, nail strip snap-lock panel configuration with a 20 in. (508 mm) coverage.

FP 1300/16

Runs a fixed width, variable length, single-profile 1.5 in. (38.1 mm) high x 0.5 in. (12.7 mm) wide mechanically seamed panel, configuration with a 16 in. (406.4 mm) coverage.

MetalMan Fixed Panel Roofing Machines

Model	FP 1000/16	FP 1000/20	FP 1101/16	FP 1101/20
Part Number	01647 PA	01647 PC	01643 PA	01643 PC
Dimensions (in)	123 x 31.5 x 29	123 x 35.5 x 29	123 x 31.5 x 29	123 x 35.5 x 29
Dimensions with rack	123 x 36.5 x 53	123 x 40.5 x 53		
Weight (lbs)	Approx. 1900	Approx. 2000	1900	2000
Power 1.5 HP Electric Motor 120V/20AMP	✓	✓	✓	✓
Drive 4 polyurethane drive roller stations - chain driven	✓	✓	✓	✓
Shear Easy cut rack and pinion manual hand shear	✓	✓	✓	✓
Speed	40 ft/min	40 ft/min	40 ft/min	40 ft/min
Materials Formed Steel 30-24 gauge painted, galvanized, aluminized	✓	✓	✓	✓
Aluminum .019 -.032 in.	✓	✓	✓	✓
Copper 16-20 oz. (min. 1/2 hard)	✓	✓	✓	✓

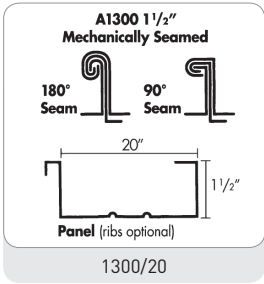

FP 1300/20

Runs a fixed width, variable length, single-profile 1.5 in. (38.1 cm) high x 0.5 in. (12.7 mm) wide mechanically seamed panel, configuration with a 20 in. (508 mm) coverage.

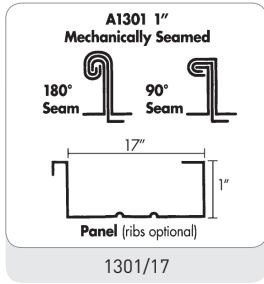

FP 1301/17

Runs a fixed width, variable length, single-profile 1 in. (2.5 cm) high x 0.5 in. (12.77 mm) wide mechanically seamed panel configuration with a 17 in. (431.8 mm) coverage.

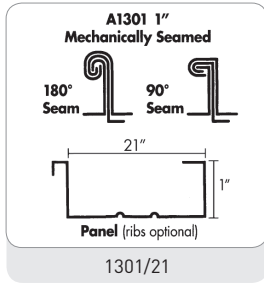

FP 1301/21

Runs a fixed width, variable length, single-profile 1 in. (2.5 cm) high x 0.5 in. (12.77 mm) wide mechanically seamed panel configuration with a 21 in. (533.4 mm) coverage.

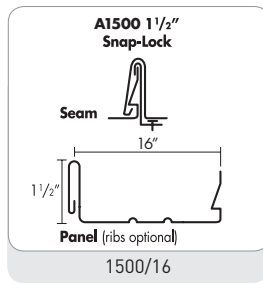

FP 1500/16

Runs a fixed width, variable length, single-profile 1.5 in. (38.1 cm) high x .25 in. (6 mm) wide snap-lock panel, configuration with a 16 in. (406.4 mm) coverage.

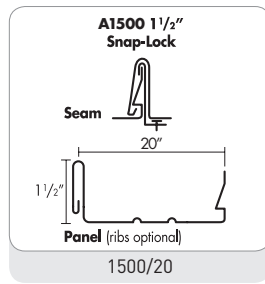

FP 1500/20

Runs a fixed width, variable length, single-profile 1.5 in. (3.8 cm) high x 0.25 in. (5 mm) wide snap-lock panel, configuration with a 20 in. (508 mm) coverage.

FP 1300/16	FP 1300/20	FP 1301/17	FP 1301/21	FP 1500/16	FP 1500/20
01640 PA	01646 PA	01641 PA	01642 PA	01645 P	01645 PA
123 x 31.5 x 29	123 x 35.5 x 29	123 x 31.5 x 29	123 x 35.5 x 29	123 x 31.5 x 29	123 x 35.5 x 29
1900	2000	1900	2000	1900	2000
✓	✓	✓	✓	✓	✓
✓	✓	✓	✓	✓	✓
✓	✓	✓	✓	✓	✓
40 ft/min	40 ft/min	40 ft/min	40 ft/min	40 ft/min	40 ft/min
✓	✓	✓	✓	✓	✓
✓	✓	✓	✓	✓	✓
✓	✓	✓	✓	✓	✓

Specifications subject to change without notice.

MetalMan Multi-Panel Roofing Machine

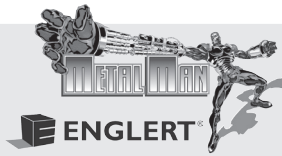

MetalMan Multi-Panel Roll Former, Infinitely Adjustable Panel Widths From 12" - 24" (304.8 mm - 609.6 mm)

Englert Inc. brings in-plant manufacturing to the job site. Introducing the Englert Multi-Panel Roll Former, a state-of-the-art roll forming machine that will run more sizes, gauges and types of material in more panel configurations with minimum adjustments and less scrap. On-site fabrication eliminates shipping damage, short shipments and many sizing errors plus provides packaging and freight savings.

Englert Roll Formers means better products, less problems and lower costs.

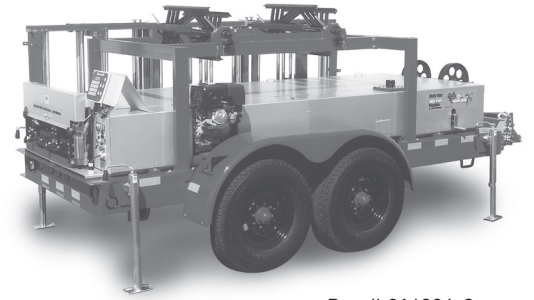

Part# 01639A Gas
Part# 01638Z Electric

METALMAN ROOFING MACHINES

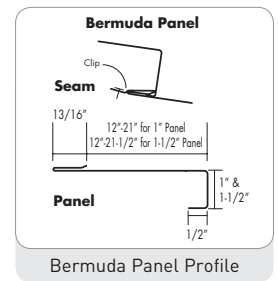
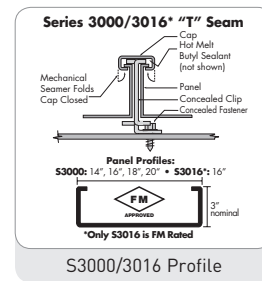
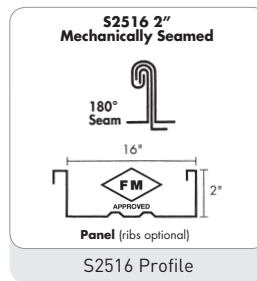
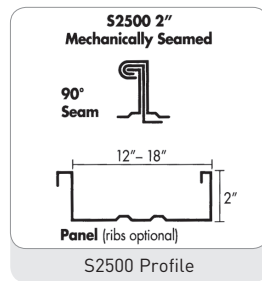
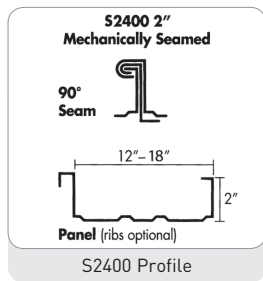
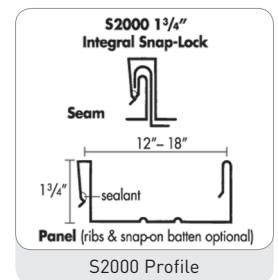
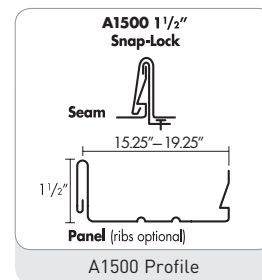
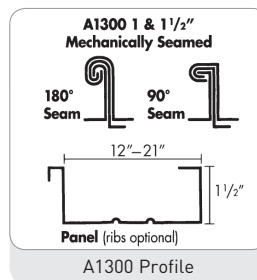
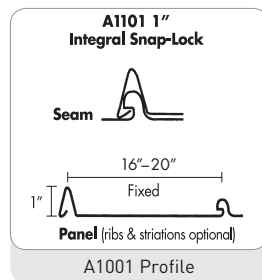
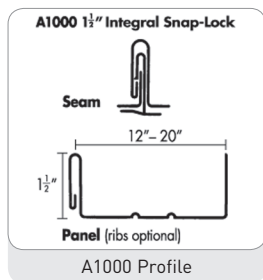

FEATURES:

- Chrome plated forming roller systems.
- Infinitely variable full cycle shear.
- Clip Relief and/or Stiffening Ribs can be added to any Panel Profile.
- Striated Paneling Rollers also available.
- Separate drive and form rollers, eliminates most oil canning.
- Hydraulic drive system and shear are electrically activated.
- Integrated Electric Hot Melt Sealant Pump System controls.
- Forming roller systems can be changed out in about 1 hour depending upon experience of operator.
- Limited 5 year warranty.

AVAILABLE OPTIONS:

- 12,000 LB. capacity tandem axle trailer (Part# 01639LA).
- Dual reel overhead decoiler and expandable arbors.
- 50' of variable height run out stands.
- Electric Seamers for use with A1300/A1301, S2400/S2500 or 3000 panels.
- Electronic computer controller.
- Hot Melt sealant pump system.
- Hand Seamers: 2500/2400 - 1300/1301 - 3000
- 7 1/2" HP Electric Motor, 220V 3PH. 60 Hz. standard - call your local Englert rep for power options.

SPECIFICATIONS:

PANFORMER:

Length - 12' (3.657 m)
Width - 4'5" (1.364 m) plus engine projection
Height - 1'3" (.381 m) plus engine projection

PANFORMER ON TRAILER:

Length - 17'2" (5.232 m)
Width - 7'3" (2.21 m)
Height - 6'3" (1.905 m) with reel
Weight - 3990 lbs. (1810 kg)

POWER:

13 H.P. Electric Start Honda Gas Engine.

DRIVE:

16 hydraulically powered chain driven cast polyurethane drive rollers.

SHEAR:

Electrically activated, hydraulically powered, infinitely adjustable, full cycle.

SPEED:

Approximately 90 ft. (27.43 m) / minute. Speed should be decreased 25-50% when using sealant pump depending on temperature.

MATERIALS FORMED:

Steel - 30 gauge to 22 gauge
(painted, galvanized, galvalume aluminized)
Aluminum - .019" (.48 mm) to .040" (1.02 mm)
Copper - 16 oz. to 20 oz. (min. 1/2 hard)

Specifications subject to change without notice.

MetalMan 90° 1" or 1 1/2" Electric Seamer



MetalMan 90° 1" or 1 1/2" Electric Seamer

Part Number 01628P

The Englert MetalMan E1300/1301 90° 1" or 1 1/2" Electric Seamer produces a 90° seam in two directions, saving you time and money on your seaming jobs.

This lightweight seamer has an innovative, patented drive system that minimizes drive system wear. Seaming 90° and 180° seams separately gives your panels a tighter seam and better looking finished product.

TECHNICAL DATA:

Length	19" (48.3cm)
Width	19" (48.3 cm)
Height	16" (40.7 cm)
Weight	54 lbs. (35.98 kg)
Power	115V, 1 Phase
Speed	45 Ft/Minute

FEATURES:

- 1/2 HP motor, gear driven
- Forward/reverse switch
- Jog/run switch
- Panel end proximity switch
- Adjustable wheel heights
- 90° seam capability
- Aluminum storage case

MATERIAL FORMED:

Steel - 30 gauge to 24 gauge
(painted, galvanized, aluminized)
Aluminum - .019" (.48mm) to .040" (1.02mm)
Copper - 16 oz. to 20 oz.

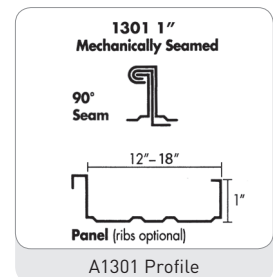
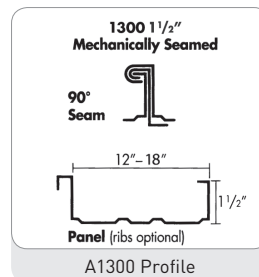
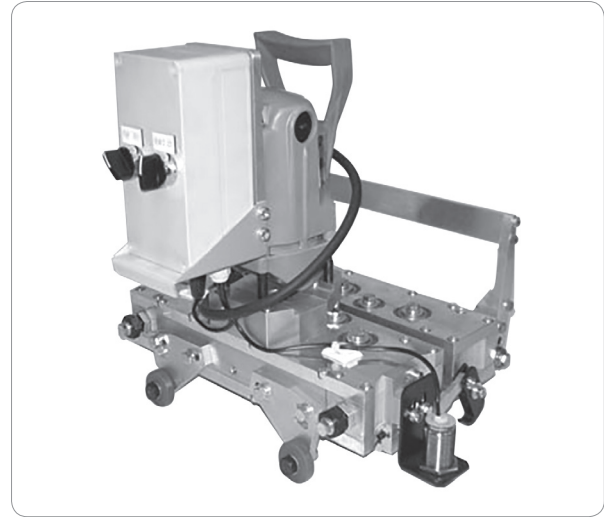

CURVERS AND SEAMERS

Specifications subject to change without notice.

MetalMan 180° 1" or 1 1/2" Electric Seamer

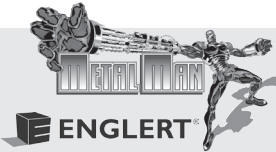

MetalMan 180° 1" or 1 1/2" Electric Seamer

Part Number 01629P

The Englert MetalMan E1300/1301 – 180° - 1" or 1 1/2" Electric Seamer produces a 90° seam in two directions, saving you time and money on your seaming jobs.

This seamer has an innovative, patented drive system that minimizes drive system wear. Seaming 90° and 180° seams separately gives your panels a tighter seam and better looking finished product.

TECHNICAL DATA:

Length	23" (58.42 cm)
Width	18" (45.72 cm)
Height	21" (53.34 cm)
Weight	8.7 lbs. (35.98 kg)
Power	115V, 1 Phase
Speed	45 Ft/Minute

FEATURES:

- 1/2 HP motor, gear driven
- Forward/reverse switch
- Jog/run switch
- Panel end proximity switch
- Adjustable wheel heights
- 90° and 180° seam capability
- Aluminum storage case

MATERIAL FORMED:

Steel – 30 gauge to 24 gauge
(painted, galvanized, aluminized)
Aluminum – .019" (.48mm) to .040" (1.02mm)
Copper – 16 oz. to 20 oz.

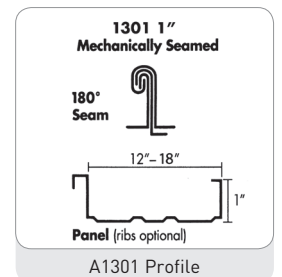
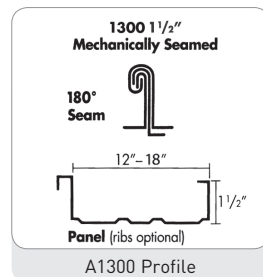
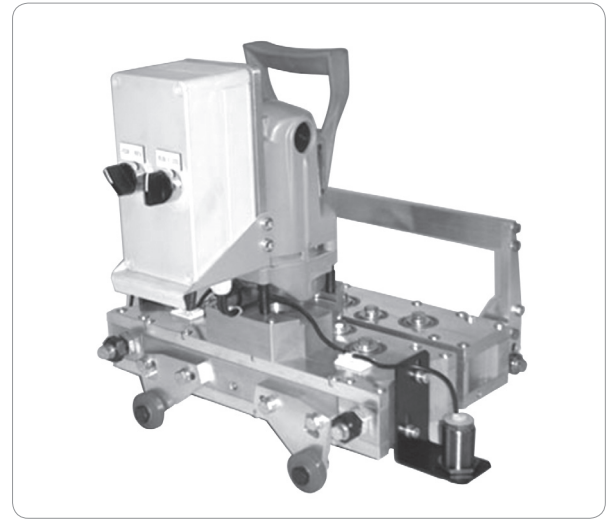

Specifications subject to change without notice.

MetalMan E2 2" Seamer



**MetalMan
E2 2" Seamer**
Part Number 01627P

The MetalMan E2 Electric Seamer produces either 90° or 180° seams on a 2" series 2400/2500 panel. This is the only seamer that can handle 22 gauge metal with a heavy duty 6" stainless steel clip.

The MetalMan E2 Electric Seamer comes with an extra set of 90° tooling to run up and down the roof.

TECHNICAL DATA:

Length 23" (58.42 cm)
Width 18" (45.72 cm)
Height 21" (53.34 cm)
Weight 87 lbs. (35.98 kg)
Power 115V, 1 Phase
Speed 35 Ft/Minute

FEATURES:

- ½ HP motor, gear driven
- Forward/reverse switch
- Jog/run switch
- Panel end proximity switch
- Adjustable wheel heights
- Two position locking handle
- 90° and 180° seam capability
- Extra set of 90° rollers
- Aluminum storage case

MATERIAL FORMED:

Steel - 30 gauge to 22 gauge
(painted, galvanized, aluminized)
Aluminum - .019" (.48mm) to .040" (1.02mm)
Copper - 16 oz. to 20 oz.

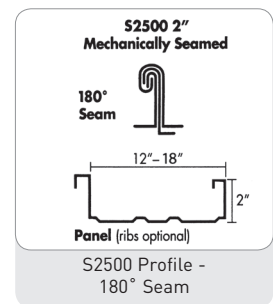
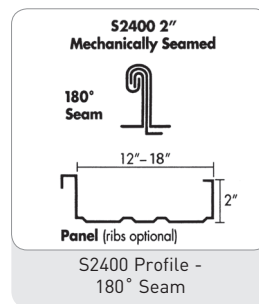
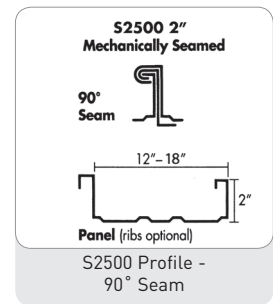
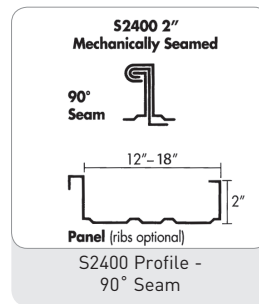

CURVERS AND SEAMERS

Specifications subject to change without notice.

1" or 1 1/2" Panel Curving Machine

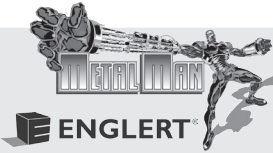

1" or 1 1/2" Panel Curving Machine Part Number 01607F

The curved 1300 system, at 1 1/2" tall, can be brought down to a minimum radius of 36" in aluminum or 100" in steel. This system, although rugged in design, requires a solid deck for installation, and carries the 1300 UL Listing (16" width) with proper fastening.

Both the 1" and 1 1/2" profiles can be locked with a 90° fold or a slim 180° fold. Panel widths for this application are infinitely adjustable from 12" to 28" in all metals and seam configurations. This system curves panels formed on Englert roll formers (models 1300 and 1301 only).

**Articulated seamer required. Please consult with your Englert sales representative for details.*

TECHNICAL DATA:

Length 39.5" (100.33 cm)
Width 45" (114.30 cm)
Height 64.9" (164.85 cm)
Weight 617.4 lbs. (280.05 kg)
Power 115V, 1 Phase, 1.0 HP AC Motor
Speed 40 Ft/Minute

MINIMUM RADIUS 1":

Steel – (24 gauge) 60" (152.4 cm)
Copper – 24" (60.96 cm)
Aluminum – 24" (60.96 cm)

MINIMUM RADIUS 1 1/2":

Steel – (24 gauge) 100" (245 cm)
Copper – 36" (91.94 cm)
Aluminum – 36" (91.44 cm)

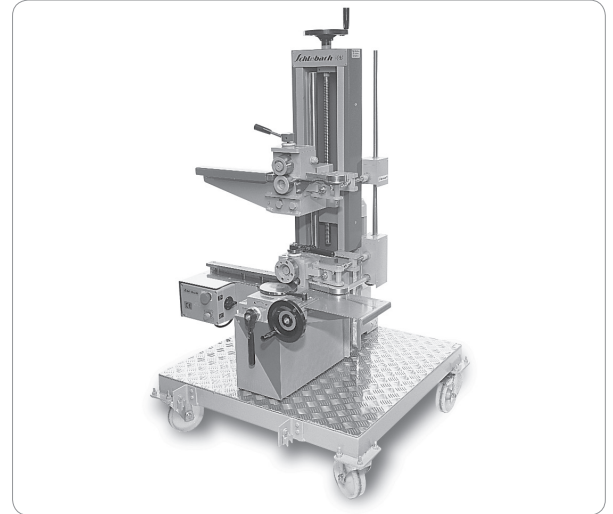

A1300 1 & 1 1/2" Mechanically Seamed

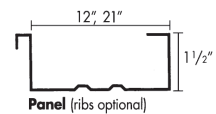

Straight
Back Profile

MATERIAL FORMED:

Steel – 29 gauge to 22 gauge
(painted, galvanized, aluminized)
Aluminum – .019" (.48mm) to .040" (1.02mm)
Copper – 16 oz. to 20 oz. 3/4 hard

Specifications subject to change without notice.

2" Panel Curving Machine



2" Panel Curving Machine Part Number 01607A

The curved 2400 system, at 2" tall, can be brought down to a minimum radius of 36" in aluminum or 100" in steel. This system, although rugged in design, requires a solid deck for installation, and carries the 2400 UL listing (18" width) with proper fastening. The 2" profile can be locked with a 90° fold. Panel widths for this application are infinitely adjustable from 12" to 28" in all metals. The system curves series 2400 panel profiles.

TECHNICAL DATA:

Length 39.5" (100.33 cm)
Width 45" (114.30 cm)
Height 64.9" (164.85 cm)
Weight 617.4 lbs. (280.05 kg)
Power 115V, 1 Phase, 1.0 HP AC Motor
Speed 40 Ft/Minute

MINIMUM RADIUS 2":

Steel - (24 gauge) 100" (254 cm)
Copper - 36" (91.44 cm)
Aluminum - 36" (91.44 cm)

MATERIAL FORMED:

Steel - 29 gauge to 22 gauge
(painted, galvanized, aluminized)
Aluminum - .019" (.48mm) to .040" (1.02mm)
Copper - 16 oz. to 20 oz. ¾ hard

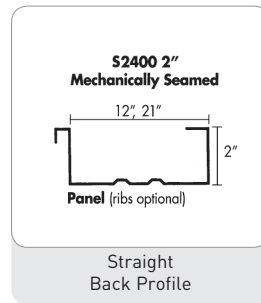
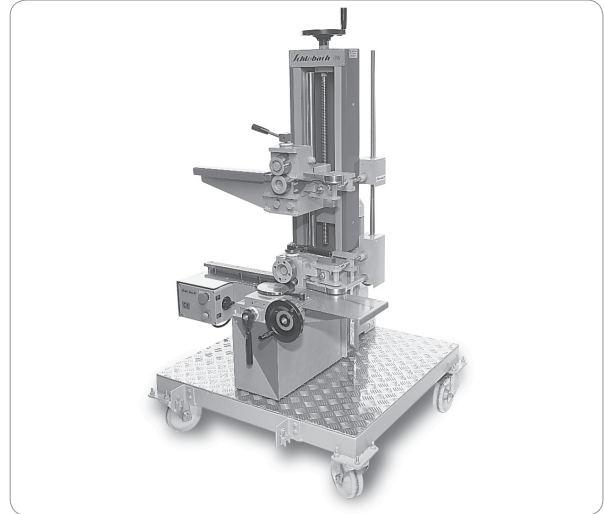

CURVERS AND SEAMERS

Specifications subject to change without notice.

1.800.610.1975 www.englertinc.com

MetalMan 770 7" SEAMLESS BOX GUTTER MACHINE



MetalMan 770 Box Gutter Machine

Part Number 01321PA

Englert, Inc. revolutionizes the gutter machine industry with the 770 Gutter Machine... the most versatile to hit the market in 30 years.

Separate polyurethane drive roller system drives all materials up to 22 gauge steel through the machine with ease. The polyurethane drive rollers are guaranteed for life against separation from the drive hubs under normal operating conditions.

Chromed free floating forming rollers eliminate the excessive pressure of driven forming rollers. This allows a much wider variety of materials to be run through the machine with little or no adjustments, making the 770 Gutter Machine the most advanced and versatile machine on the market.

Rack and pinion shear and hardened tool steel cutting dies ensure long life and easy cutting of all materials up to 22 gauge steel.

Transporting the new, high tech 770 Gutter Machine saves on coil too! Especially in comparison to yesterday's gutter rollformer technology. Material need to be loaded and left in the machine to prevent damage and misalignment, when moving from job to job, which means less wasted material and more profit.

FEATURES:

- Free floating chromed forming rollers
- Mechanical guillotine utilizing rack and pinion shear
- Exit end reversing drum switch with exit end 20 amp., 120V., weatherproofed double outlet
- Limited 5 year parts warranty

AVAILABLE OPTIONS:

- Adjustable 4" flange kit (from -5° to 15°) (Part Number 01320P)
- Gutter stands
- Extra reels
- Specially designed trailer (Part Number 01321T)
- Hem back kit

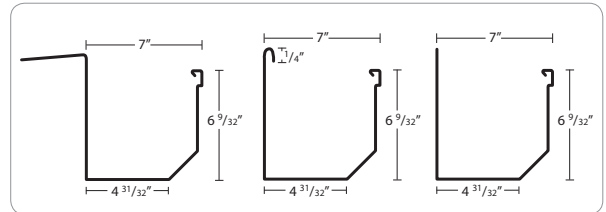

Adjustable Flange
Back Profile

Hem
Back Profile

Straight
Back Profile

SPECIFICATIONS:

Length: 183" (15.25')
Width: 30"
Height: 20"
Machine Weight: 2,575 lbs.
Machine and Trailer Weight: 5,101 lbs.

POWER:

1.5 HP., 110V., 1 PHASE TEFC MOTOR. Dedicated powered polyurethane drive rollers via chains and sprockets.

SHEAR:

Mechanical guillotine using rack and pinion system.

SPEED:

Approximately 45 feet per minute.

CONTROLS:

Reversing drum switch with entry and exit end emergency stop switches.

FORMING:

Factory set free floating chromed forming rollers.

FRAME CONSTRUCTION:

Welded tubular steel frame.

MAXIMUM GAUGE OF MATERIALS FORMED:

Up to 22 gauge steel
Up to .040" aluminum

Specifications subject to change without notice.

RAS TURBO**end** & SMART**cut** Machines

RAS TURBO**end**

Designed for the roofing, architectural, and metal construction markets, the TURBO**end** is completely revolutionary from its simple-to-use-control to its fast, sophisticated, easy to use, and accurate folding system. It is simply the best folding system on the market today.

The incredible thing about the TURBO**end** is its perfect combination of machine quality and user-friendly controls. We have manufactured the most rigid machine components and incorporated them into a solid, extremely accurate machine. You will be amazed how quick, accurate and easy you will complete a part in the future. As material thickness changes, the machine automatically sets itself to the new material. Forget about old fashioned adjustments on the folding beam. Don't compromise! You earn your money with quality parts that fit and can be assembled on the construction site as quickly as possible.

Where does all this precision and speed come from?

RAS engineers utilize Finite Element Analysis to design each machine component for an optimum of low deflection, tension and torsion. This system provided them the means to develop a folding beam that twists less than 5/1000 of a degree under full 1.5 mm (16 gauge) load. One look at the deep and robust folding beam and you know why the bends are so incredibly accurate.

RAS has used the most modern control technology and highest dynamic drive motor system to rotate the folding beam. The machine performs at blinding fast speed of 80 degrees per second precisely to the correct programmed angle. The backgauge system, incorporating AC-servo motors, positions the part for each bend. The standard backgauge system is extremely versatile, compact, accurate and fast. The machine is easily located into a very small, compact space.



RAS TURBO**end**



RAS Touch & More Control

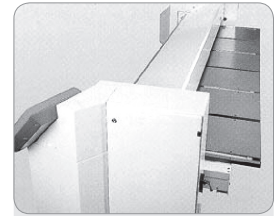

124" Long 16 gauge

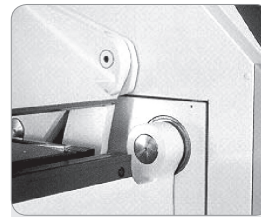

The Innovative Eccentric Elbow Pivot and Drive Shaft System

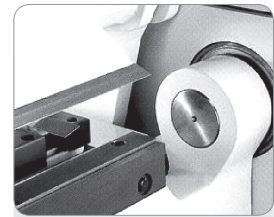

Upper & Lower Clamping Beams

RAS SMART**cut**

The RAS SMART**cut** combines all features you expect from shears - complete in the standard version. The swing beam system ensures right-angled and twist-free cuts. The sheet support and sorting system guides even thin metals reliably to the backgauge and sorts finished parts to the front or the rear.

If the blades need to be sharpened, simply unscrew them and slide them out either side. The machine will be up and running again quick, as the crowning is already machined into the beam and the blade clearance can be adjusted in seconds.

Swing Beam - Modern Technology

The innovative RAS SMART**cut** uses the modern swing beam technology and not the traditional guillotine concept. This means: twist-free cutting of even small strips, no material getting stuck and longer lifetime for the blades.

FEATURES:

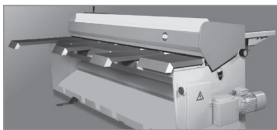

RAS SMART**cut**

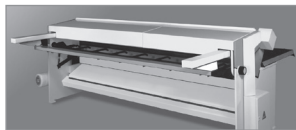

Front Stop

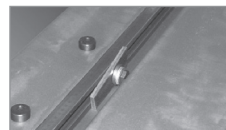

Clamping Stop Lever in Position

Foot Lever for Parts Chute

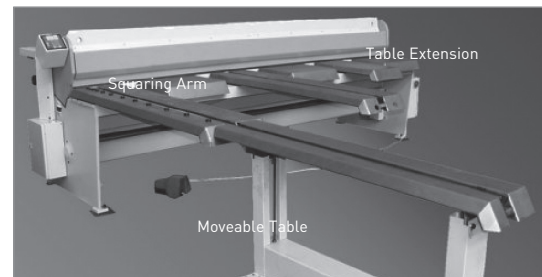

Squaring Arm

Table Extension

Moveable Table

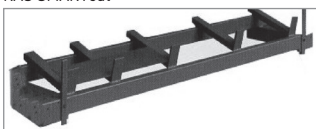

Parts Collector

Specifications subject to change without notice.

Material Conversion and Usage Information

MATERIAL CONVERSIONS

Material	Gauge	Thickness	Lbs. Per Sq. Ft.
Aluminum	26	.016	.230
Aluminum	25	.018	.259
Aluminum	21	.028	.403
Aluminum	20	.032	.461
Aluminum	18	.040	.576
Aluminum	16	*.050	.720
Aluminum	14	.063	.907
Aluminum	12	.080	1.15
Copper	16 oz.	.0216	1.00 (3/4 Hard)
Copper	20 oz.	.0270	1.25 (1/2 Hard)

Material	Gauge	Thickness	Lbs. Per Sq. Ft.
G-90 & Galvalume®	28	.016	.650
G-90 & Galvalume®	26	.018	.733
G-90 & Galvalume®	24	.023	.943
G-90 & Galvalume®	22	.029	1.27
G-90 & Galvalume®	20	.040	1.66
Stainless	28	.0156	.656
Stainless	26	.0188	.788
Stainless	24	.0250	1.05

*NOTE: Englert cannot paint anything thicker than .050

METAL GAUGE VS. THICKNESS

Gauge	Steel	Aluminum, Brass, Copper	Gauge	Steel	Aluminum, Brass, Copper
7	.179	.144	18	.048	.040
8	.164	.128	19	.042	.036
9	.149	.114	20	.036	.032
10	.134	.102	21	.033	.028
11	.120	.090	22	.030	.025
12	.105	.080	23	.027	.022
13	.090	.072	24	.024	.020
14	.075	.064	25	.020	.018
15	.067	.057	26	.018	.016
16	.060	.050	27	.016	.014
17	.054	.045	28	.015	

SLOPE FACTORS

When Scaling A Roof Size From A Drawing, Multiply Roof Area x Slope Factor = Total Area			
2/12	Roof Area x 1.0147	=	Total Area
3/12	Roof Area x 1.031	=	Total Area
4/12	Roof Area x 1.054	=	Total Area
5/12	Roof Area x 1.083	=	Total Area
6/12	Roof Area x 1.118	=	Total Area
7/12	Roof Area x 1.158	=	Total Area
8/12	Roof Area x 1.202	=	Total Area
9/12	Roof Area x 1.250	=	Total Area
10/12	Roof Area x 1.302	=	Total Area
11/12	Roof Area x 1.357	=	Total Area
12/12	Roof Area x 1.413	=	Total Area

SYSTEM MATERIAL USAGE

Series	Coil Size	Panel Size	Material Usage (Diff)	Panel Size Variable	Max. Material Thickness
A 1000 [1-1/2" Snap-Lock System]	24"	20"	4"	12"-20"	24 Gauge
A 1100 [1-1/4" Integral Snap-Lock System]	20"	16"	4"	16"-20"	24 Gauge
A 1101 [1" Integral Snap-Lock System]	20"	16"	4"	16"-20"	24 Gauge
A 1300 [1-1/2" Mechanically Seamed System]	24"	20"	4"	12"-24"	22 Gauge
A 1301 [1" Mechanically Seamed System]	24"	21"	3"	13"-21"	22 Gauge
A 1500 [1-1/2" Integral Snap-Lock System]	24"	19.25"	4.75"	15.25"-19.25"	22 Gauge
C 1300 [1-1/2" Curved Mechanically Seamed System]	24"	20"	4"	12"-24"	24 Gauge
C 1301 [1" Curved Mechanically Seamed System]	24"	21"	3"	13"-21"	24 Gauge
C 2400 [2" Curved Mechanically Seamed System]	24"	18"	6"	12"-24"	22 Gauge
S 2000 [1-3/4" Integral Snap-Lock System]	24"	18"	6"	12"-18"	22 Gauge
S 2400 [2" Mechanically Seamed System]	24"	18"	6"	12"-24"	22 Gauge
S 2500/2516 [2" Mechanically Seamed System]*	22"	16"	6"	12"-18"	22 Gauge
S 3000/3016 [3" T-Seam Mechanically Seamed System]*	26"	20"	6"	12", 14", 16", 18", 20"	20 Gauge
A 4000 [1-1/2" Flush Wall Panel]	24"	18"	6"	12"-24"	22 Gauge
B 4000 [1" Flush Soffit Wall Panel]	24"	20"	4"	12"-24"	22 Gauge

*Sun tested version available, see Englert for details.

PANEL COVERAGE VS. MATERIAL USAGE

For Systems Using 4" of Metal In Seams					
	Panel Widths	Panel Widths	Panel Widths	Panel Widths	Panel Widths
Effective Panel Coverage [Panel Width]	12"	16"	18"	20"	24"
Metal Required To Rollform One Linear Foot Panel	16"	20"	22"	24"	28"
Sq. Ft. Of Coil Required To Rollform One Square (100 Sq. Ft.) Of Metal Roof	133	125	123	120	117
Percentage Of Coil Metal Needed To Cover The Roof Area (100 X)	1.33	1.25	1.23	1.20	1.17
For Systems Using 6" of Metal In Seams					
	Panel Widths	Panel Widths	Panel Widths	Panel Widths	Panel Widths
Effective Panel Coverage [Panel Width]	12"	16"	18"	20"	24"
Metal Required To Rollform One Linear Foot Panel	18"	22"	24"	26"	30"
Sq. Ft. Of Coil Required To Rollform One Square (100 Sq. Ft.) Of Metal Roof	150	137	134	130	125
Percentage Of Coil Metal Needed To Cover The Roof Area (100 X)	1.50	1.375	1.34	1.30	1.25

TO DETERMINE COIL REQUIREMENTS OF A GIVEN JOB

Simply take the roof area to be covered, and depending upon panel width, multiply it by a percentage of metal needed to cover the total roof area.

Thus, to cover a 10,000 sq. ft. area using an 18" wide panel with 6" of metal in the seams, you would need to multiply 10,000 x 1.34 or you would need 13,334 sq. ft. of coils.

THIS CALCULATOR IS FOR ESTIMATION PURPOSES ONLY. FOR PRECISE INFORMATION ON CALCULATING COIL PURCHASES, CONTACT: THE ENGLERT CUSTOMER VALUE CENTER AT 1-800-ENGLERT (1-800-364-5378) FOR MORE INFORMATION AND ASSISTANCE.



Installation Common Sense and Material Handling

STORAGE AND PROTECTION OF PAINTED COILS

Painted coils are inspected by Englert Inc. quality control inspectors and approved for shipment to you. Inspect the coil immediately for shipping damage. If any damage is found, promptly advise the carrier and file a freight claim.

PROTECT YOUR PAINTED MATERIAL

If moisture entrapment is permitted on the painted coils, white rust/rust can quickly develop. White rust/rust will attack the painted surface. To prevent that from happening, observe the following:

1. Provide inside storage. Painted material stored outside is not warranted.
2. Making provisions for adequate air flow in storage area.
3. During periods of extreme temperature change, provide heat to prevent concealed condensation.
4. Storage beyond six months is not recommended and may result in damage to your painted material.
5. Forming of painted material in temperatures of less than 40 degrees F, may produce unsatisfactory results.
6. Damage to the paint surface may result if formed sheets are stored at the job site and are exposed to excessive moisture.

Pre-coated steel and aluminum coils have been successfully used for many years in the rollforming of roofing panels on site. In general, corrosion problems have been minimal on properly installed building panels under normal exposure. However, pre-coated steel panels are subject to premature corrosion failures prior to erection on the building, if they are not handled properly between coating and ultimate utilization, namely, rollforming/installation on job site. Usually discovered at the job site, the problem is evidenced by "white rust" along rollformed ribs in the panels.

The following are some recommendations to address the problem of job site corrosion of pre-coated steel coils and panels. The recommendations are an outgrowth of intensive study of the job site corrosion problem by suppliers in the metal panel industry. All areas felt to be pertinent to prevention of white rust, from coating system selection to job site storage and rollforming are covered.

COATINGS SELECTION AND APPLICATION

The following guidelines are specific toward minimization of job site corrosion problems. Other properties such as weatherability, color, gloss, etc., depend on the specific end use, and are not considered here. It is recognized that water must be present for white rust corrosion to occur, regardless of the quality of the finished coils and panels. Hence, the primary requirement of the coating system is resistant to white rusting under humid exposure.

Normal prepainted coils received, properly stored, and used right away in a few weeks time from Englert for on site rollforming should not present a white rust problem, unless the coils are stored over several months.

If a large amount of coil is required for rollforming, for which there will be no immediate use (in a few weeks), order your material in stages as you need it, over a period of time, so you will be able to manufacture coils into panels, without storing them in the open over an extended period of time.

FABRICATION

1. The radius of rollformed areas on panels should not be less than four times the thickness of base metal. For example, the minimum bend radius of 0.021" metal would be 0.084".
2. Forming equipment should be checked and maintained regularly so that bend radii are maintained above the gauge minimum, and surface abrasion is minimized. Typical problems to be aware of are roll alignment, roll speed synchronization, roll build-up, roll wear, and general cleanliness.
3. Lubricants, such as wax, can be beneficial for rollforming and can help to minimize transit abrasion. However, lubricants should be checked prior to use to be sure that there are no detrimental effects on the paint film, such as softening, gloss change, etc. If water based waxes are used, thorough drying must be insured. In addition, the lubricity of wax coatings can present a serious slippage hazard during building erection, particularly on roofs.
4. Protect coils with cover sheets; other wrapping material may be used provided that it is non-absorbent, non-staining, and with the understanding that outdoor durability is limited. Wrapping should be applied such that there are no folds or laps situated in such a manner as to catch and hold water.
5. Caution should be exercised when loading and unloading coils to prevent damage it can present in rollforming. Tarps must be used to cover the coils, not only to prevent entry of water into the coils, but also to prevent contamination of the coils with diesel smoke and road dirt.

JOB SITE STORAGE

1. Under-roof storage is more desirable, and should be used whenever practical. Job site storage time should be minimized.
2. When stored outdoors, coils should be placed in a manner to promote good drainage. There should be at least six inches of clearance between the lower end of the coils and the ground to allow good ventilation.
3. Complete encapsulating plastic wrap should be removed, if present, and plastic tarps or shrouds should not be placed over the coils in such a manner as to prevent good ventilation. The "humidity cabinet" effect of unventilated plastic wrapping is well known, and results in interior temperatures far higher than the surrounding air temperature. Such high temperatures, in conjunction with entrapped moisture, rapidly accelerate corrosion reactions, regardless of the quality or type of the coating system.
4. Inspect each coil upon arrival for any damage, corrosion or wet coils. If water is already present in any coil, it should be broken open, drained, and spread to allow complete drying. Coils already showing corrosion failure should be brought to the immediate attention of the supplier.
5. Special storage and handling instructions, as recommended for Mill Finish Galvalume products must be followed, as recommended elsewhere in this catalog, in order to assure satisfactory final results.

Adapted from the Technical Bulletin of:
Coatings Classifications and Definitions
Committee of National Coils Coaters
Association for Storage and Maintenance Of Prepainted Coils for On Site Rollforming

Specifications subject to change without notice.

TERMS AND CONDITIONS

These Sales Terms and Conditions ("Terms") govern all sales of products ("the Products") by Englert, Inc. ("Seller") to Buyer regardless of whether Buyer purchases the Products through the medium of written purchase orders, telephonic orders, or electronic orders (collectively, "Purchase Orders"). Upon receipt by Seller of an express acceptance by Buyer or upon commencement of performance by Seller, these Terms and the face of the Purchase Order, as modified by Seller's acceptance or order acknowledgment, become a binding contract between Buyer and Seller on the terms reflected in those documents. In the event of a conflict between these Terms and the face of the Purchase Order, these Terms prevail except where Seller has expressly agreed to the conflicting term(s) in the Purchase Order in Seller's written acceptance or order acknowledgment. In all cases, any and all terms and conditions as may be contained in any request for quotations, request for bids, purchase orders and similar documents issued by Buyer are hereby expressly rejected in their entirety and shall have no force or effect. Seller is not responsible for typographical or clerical errors made in any quotations, orders or publications. All such errors are subject to correction.

1. ACCEPTANCE: ALL SALES ARE SUBJECT TO AND EXPRESSLY CONDITIONED UPON THE TERMS AND CONDITIONS CONTAINED HEREIN, AND UPON BUYER'S ASSENT THERETO. NO VARIATION OF THESE TERMS AND CONDITIONS WILL BE BINDING UPON SELLER UNLESS AGREED TO IN WRITING AND SIGNED BY AN OFFICER OR OTHER AUTHORIZED REPRESENTATIVE OF SELLER.

2. CHANGES: Orders arising hereunder may be changed or amended only by written agreement signed by both Buyer and Seller, setting forth the particular changes to be made and the effect, if any, of such changes on the price and time of delivery. Buyer may not cancel the Purchase Order unless such cancellation is expressly agreed to in writing by Seller. In such event, Seller will advise Buyer of the total charge for such cancellation, and Buyer agrees to pay such charges, including, but not limited to, storage and shipment costs, costs of producing non-standard materials, costs of purchasing non-returnable materials, cancellation costs imposed on Seller by its suppliers, and any other cost resulting from cancellation of the Purchase Order by Buyer which is permitted by Seller. Certification of such costs by Seller's independent public accountants shall be conclusive on the parties hereto.

3. SHIPMENT: The method of packing and shipment of the Products sold hereunder shall be at the discretion of the Seller, unless otherwise agreed to by the parties.

4. DELIVERY: Seller reserves the right to make delivery in installments. Delay in delivery of any installment shall not relieve Buyer of Buyer's obligations to accept remaining deliveries. If a delivery is delayed as a result of any action or inaction of Buyer, Seller may invoice Buyer for the Products as of the scheduled delivery date and may charge Buyer for warehousing and other expenses incurred because of the delay. Seller's obligation with respect to delivery ceases upon its tendering possession of the Products to the first common carrier at Seller's facility. Thereafter, all risk of damage, loss or delay in transportation shall be borne of the Buyer.

5. INSPECTION: Immediately upon Buyer's receipt of any goods shipped hereunder, Buyer shall inspect the same and shall notify Seller in writing of any claims for shortages, defects or damages and shall hold the goods for Seller's written instructions concerning disposition. If Buyer shall fail to so notify Seller within five (5) calendar days after the goods have been received by Buyer, such goods shall conclusively be deemed to conform to the terms and conditions hereof and to have been irrevocably accepted by the Buyer.

6. EXCUSABLE DELAY: Seller shall not be liable for any loss, damage or penalty as a result of any delay in or failure to manufacture, deliver or otherwise perform hereunder due to any cause beyond Seller's reasonable control, including, without limitation, act of Buyer, embargo or other governmental act, regulation or request affecting the conduct of Seller's business, fire, explosion, accident, theft, vandalism, riots, insurrection or sabotage, floods, labor difficulties, lightning, windstorm, or other catastrophes or acts of God, unusually severe weather, accidents, epidemics or quarantine restrictions, acts of local, state or national governments, or public agencies, labor disputes or shortages, energy or material shortages, utility or communication failures or delays, threats or acts of terrorism, delays of a supplier of Seller, or causes beyond the reasonable control and without the fault or negligence of Seller. In the event of any such delay, the date of delivery shall be deferred for a period equal to the time lost by reason of the delay.

7. PAYMENT: Payment will be due from Buyer as deliveries are made by Seller, unless a deposit is required in the case of a special order and specified on the face of the Purchase Order. Payment of all sums invoiced to Buyer shall be in U.S. currency. In the event delivery is made in installments, all such installments will be separately invoiced and paid for when due per invoice, without regard to subsequent deliveries.

8. PRICES – ADJUSTMENTS: The prices stated on the face of Seller's quotation apply only to Products scheduled for shipment as detailed on Buyer's purchase order and acknowledged by Seller. Notwithstanding the foregoing, however, Seller reserves the right to increase its prices upon notice to Buyer for those shipments scheduled for delivery greater than ninety (90) days from the date of Buyer's purchase order. Buyer shall have thirty (30) days from the date of such notice to cancel its order, without charge, with respect to any Products not scheduled for shipment prior to the effective date of the price increase.

9. TAXES: In addition to the stated prices, Buyer shall pay Seller the amount of any excise, sales, use or other taxes incident to the sale of Products hereunder for which Seller may be liable or which Seller is required by law to collect unless Buyer timely provides Seller with a proper tax exemption certificate.

10. WARRANTY: Seller only warrants the Products sold to Buyer hereunder to the extent specifically set forth in Seller's Limited Exterior Building Product Finish/Base Metal Warranty. THE LIMITED EXTERIOR BUILDING PRODUCT FINISH/BASE METAL WARRANTY IS BUYER'S SOLE AND EXCLUSIVE REMEDY AND IS IN LIEU OF ALL OTHER WARRANTIES, EXPRESS OR IMPLIED, INCLUDING, WITHOUT LIMITATION, MERCHANTABILITY, FITNESS FOR A PARTICULAR PURPOSE, DESCRIPTION, QUALITY, OR PRODUCTIVENESS.

11. RETURNS AND CLAIMS: Written authorization must be obtained from Seller prior to the return of any Products. Upon Seller's verification of defect, Seller retains the option to repair, replace or issue credit, at Seller's option, for the defective product. Seller shall have the right, prior to return, to inspect at Buyer's warehouse, any Products claimed to be defective or nonconforming. Risk of loss or damage to any Products returned to Seller for adjustment shall remain with Buyer until they are received by Seller. Shipping charges for returned Products will be paid by Seller only for Products repaired or replaced pursuant to warranty. Otherwise, such charge will be Buyer's responsibility. Claims for shortages, incorrect materials or invoicing errors must be made by Buyer in writing within five (5) days after receipt of shipment. Claims for non-receipt of shipment must be made in writing within five (5) days after receipt of invoice.

12. FINANCIAL RESPONSIBILITY: In the event that Buyer fails to fulfill the terms of payment for any shipment of Products or if Seller shall have a reasonable doubt at any time as to Buyer's ability to pay for Products ordered Seller may, at its option and without liability, (i) change the terms of payment or (ii) defer further production and shipments until satisfactory performance has been made by Buyer and Seller is satisfied as to Buyer's financial ability, and such change or deferment shall not prejudice any claim for damages Seller may otherwise have against Buyer.

13. PRODUCT INSTALLATION: Buyers shall indemnify and hold harmless Seller, its directors, officers, agents and employees against all expense, loss, attorneys fees, costs, damage or liability arising from any claim or action relating to or arising from any claim of defective installation of the Product by Buyer. At the request of Seller, Buyer shall defend at its own expense all such claims or actions, provided that Seller shall be entitled at its election, to participate in such defense.

14. LIMITATION OF LIABILITY: Seller's liability for defective or nonconforming Products, whether based on breach of warranty, negligent manufacture or product liability, is exclusively limited to repair or replacement, at Seller's election, of such Products. Seller assumes no risk and shall NOT be subject to ANY liability for any damages or loss resulting from the specific use or application made of the Products. Seller's liability for any other claim, whether based on breach of contract, negligence or product liability, relating to the Products shall not exceed the price paid by Buyer for such Products. In no event shall Seller be liable for any special, incidental, consequential or other damages, including, but not limited to, loss of profits, delay claims, and claims of third parties, howsoever caused, whether by the negligence of Seller or otherwise.

15. COMPLIANCE WITH LAWS: Seller warrants and certifies that it complies with all applicable statutes, rules, regulations and orders of the United States, including those pertaining to labor, wages, hours and other conditions of hiring and employment.

16. GOVERNMENT CONTRACTS: If the Products are to be used in fulfilling a contract with the United States Government, Seller will comply with all mandatory requirements of such contract which are applicable to Seller provided that Seller has received written notice of such requirements from Buyer in sufficient time to incorporate their impact into the price and delivery schedule for such Products. In addition, Seller may at its option adopt any provisions of the FAR, DFAR, DAR or other federal statutes or regulations which are applicable to Seller.

17. WAIVER: The rights and remedies of Seller as set forth in this Agreement shall be in addition to any other rights and remedies provided in law or equity and the failure or delay by Buyer to exercise any rights or remedies hereunder shall not operate as a general waiver thereof.

18. ASSIGNMENT: Buyer shall not assign any of its rights or obligations hereunder without the prior written consent of Seller.

19. NOTICES: Any notices and other communications required or permitted to be given hereunder shall be in writing and shall be effective when delivered personally, electronically transmitted (later confirmed in writing) or air mailed, postage prepaid.

20. SEVERABILITY: In the event that one or more provisions hereof should be held to be unenforceable in any respect, this document shall be construed as if such unenforceable provision(s) had not been contained herein.

21. ENTIRE AGREEMENT: These terms and conditions supersede all other agreements, representations, warranties and undertakings of the parties with respect to the subject hereof and may not be modified except by a writing signed by an authorized employee of Seller. If Buyer and Seller have executed an overriding agreement covering the sale of Products to which this document relates, the terms of said overriding agreement shall prevail over the terms stated herein only to the extent of any conflict.

22. GOVERNING LAW: Buyer's purchase of Products hereunder shall in all respects be governed by the laws of the State of New Jersey without regard to its conflicts of laws provisions. Should it be necessary for any party to commence any legal action to enforce these Terms, the prevailing party in such action shall be entitled to recover from the unsuccessful party all reasonable attorneys' fees, costs and expenses incurred by it in the prosecution or defense of such action, and any appeal.

About Englert, Inc.

History

The Englert Corporation was founded in 1966 by Herbert U. Englert, a true pioneer in the field of site-formed seamless raincarrying products.

Clearly ahead of his time, Herb's vision was to offer quality seamless rainware to homeowners across the country through a network of independent, professional, remodeling contractors. These professionals, already in the business of providing superior products and services to a residential customer base, would be empowered to offer the highest quality gutter and accessories available in the industry, then and now.



Englert's role in the exciting evolution of the site-formed products industry has been centered on providing a single supply source to our contractor base, encompassing all phases of residential and commercial metal roofing product manufacturing and support. From our in-house coil coating and accessory production to site-forming machines and technical support, Englert remains an industry leader, for over 50-years supplying quality, service and innovation to the building industry "world wide."

Commitment

Englert is totally committed to support its customers and the metal roofing industry.

At Englert, we operate our own paint line and in-house metal processing facility. Every step of the process, slitting, rollforming and stamping, is controlled to our own strict standards. Uniform color and finish along with consistent gauge and width assures you a quality product every time. Englert's products are manufactured to exceed recognized industry standards and are subjected to a stringent 67 point quality checklist.

Englert's metal roofing and accessories are painted with our Low-gloss/ULTRA-Cool® paint finish and come in a wide array of colors. We're so confident of the performance of our finish, that we offer a 35 year limited warranty against chipping, cracking and peeling. Our Low-gloss/ULTRA-Cool® finish helps minimize "oil-canning," while being environmentally responsible.

Englert offers you responsive, experienced support as your total metal roofing, accessory and equipment resource. Our advanced nationwide distribution system assures you virtually 100% availability of products. Our customers enjoy assistance with everything from product selection to installation issues. Englert offers skilled technical service, from routine adjustments, parts and repairs, to complete machine rebuilds on all of the equipment we sell. Expert machine service is only a phone call away.

If you're in the roofing or metal roofing business, we'd be happy to show you how you can expand your bottom-line potential with our proven solutions.

Contact Englert at 1-800-610-1975



Association Memberships and Testing Organizations



ARCAT®



MEMBER



NATIONAL
COIL COATERS
ASSOCIATION



Field Service Center Locations

Connecticut

41 Warehouse Point Road
Wallingford, CT 06492

New Jersey

1200 Amboy Avenue
Perth Amboy, NJ 08861

New York

45 Dixon Avenue
Amityville, NY 11701

Virginia

8560 Virginia Meadows Drive
Manassas, VA 20109

Ft. Lauderdale, Florida

2525 Davie Road
Suite 370
Plantation, FL 33317

Massachusetts

44 Garden Street
Suite 10
Danvers, MA 01923

Pennsylvania

181 Spring Run Road Ext.
Suite 100
Coraopolis, PA 15108

Tennessee

3465 North Bend Circle
Suite C
Alcoa, TN 37701

Corporate Headquarters

1200 Amboy Avenue, Perth Amboy, NJ 08861
Phone: (732) 826-8614 Fax: (732) 826-8865

1-800-610-1975



Visit www.englertinc.com or call 1-800-ENGLERT
for the Englert locations nearest you.

©2017 Englert Inc.
All rights reserved.
90091R